

# Internal Conversion

## 1 Detection of Radiation

This section will explain some basics about the interaction between particles and materials. To understand the techniques used to detect the particles emitted from a nucleus or an atom it is necessary to understand these processes.

### 1.1 Protons and $\alpha$ Particles

When a charged particle enters a material it will slow down and also change direction. The electric field of the particle will excite electrons to higher states or will free bound electrons from the atoms in the material. If an electron gets enough energy to travel through the material it can excite other electrons, so-called secondary electrons. The possible ways of excitation depend on the material. In a gas-detector the main idea is to generate electron-ion pairs. These free charges can then be collected by applying an external voltage. In a semiconductor the idea is to excite electrons from the valence band into the conduction band creating electron-hole pairs. An applied voltage can also in this case extract the created charge. In scintillating materials the excited electrons will de-excite, sending out photons. The light can be collected and amplified with a photomultiplier, creating an electronic pulse.

The general expression for the change in energy per distance,  $dE/dx$ , for a charged particle slowing down in a material is called Bethe-Blochs formula and is given by:

$$-\frac{dE}{dx} = \left( \frac{e^2}{4\pi\epsilon_0} \right)^2 \frac{4\pi z^2 N_a Z \rho}{m_e c^2 \beta^2 A} \left[ \ln \left( \frac{2m_e c^2 \beta^2}{I} \right) - \ln(1 - \beta^2) - \beta^2 - \delta - \frac{C}{Z} \right], \quad (1)$$

where:

- $e$  is the electron charge •  $\epsilon_0$  is the permeability in vacuum
- $z$  is the incoming particle's charge in  $e$
- $\rho$  is the density of the material
- $m_e$  is the electron mass
- $C$  is the shell correction parameter
- $c$  is the speed of light
- $\beta$  is  $v/c$  for the incoming particle
- $A$  is the molar mass of the material
- $I$  is the mean excitation potential
- $\delta$  is a density correction term

Note that  $dE/dx$  is proportionated to  $z^2$ . This means for example that an alpha particle will stop much faster compared to a proton in a given material.

## 1.2 Electrons

There are reasons why the electron (and the positron) must be treated differently from the other charged particles. One reason is the small mass. One of the assumptions of the Bethe-Bloch's formula is that the mass of the incoming particle is much larger than the mass of the electrons in the material. We therefore assume the particle to move in the same direction after interacting with an electron. This can be a good approximation for incoming protons or  $\alpha$  particles, but not for electrons. Another difference is that two colliding electrons are not separable. A quantum mechanical treatment of the problem therefore introduces new terms for the electrons.

Apart from the inelastic scattering against other electrons, another mechanism will also be important, namely emission of *Bremsstrahlung*. This emission of electromagnetic radiation is due to the deceleration of the electrons when they enter the material. The cross section for Bremsstrahlung is dependent on the mass as:

$$\sigma_b = \left(\frac{e^2}{mc^2}\right)^2. \quad (2)$$

We see that Bremsstrahlung is more important for high energies, and that it must be much more important for electrons than for heavier particles like protons or  $\alpha$ -particles. For electrons at an energy of about 10 MeV, the Bremsstrahlung effect is about as large as the effect from inelastic scattering.

## 1.3 Gamma Radiation

A  $\gamma$ -photon can interact with a material in three ways:

- Photo absorption
- Compton scattering
- Pair production

### 1.3.1 Photo Absorption

The  $\gamma$ -photon can be absorbed completely by giving all its energy to an electron in the material. This electron will have the same energy as the photon (except for the small binding energy). The electron will then excite many other so-called secondary electrons. The total energy of these electrons corresponds to the photon energy, so if we can measure this total energy we get the photon energy.

### 1.3.2 Compton Scattering

If the photon only gives part of its energy to an electron in the material, the photon will continue to travel through the material, but in a new direction and with a lower energy. It can then be photo-absorbed, it can Compton scatter again, or it can escape from the material (for example from a detector). The electron that were hit will excite other electrons in the material. If the scattered photon escapes from the detector, the total electron energy will be lower than the energy of the incoming photon. In this case, the measured energy does not correspond to the  $\gamma$ -ray energy.

### 1.3.3 Pair Production

If the  $\gamma$ -photon has enough energy, it can interact with the electromagnetic field of a nucleus and create an electron-positron pair. The positron will soon find an electron in the material and this electron will annihilate with the positron after a short time, creating two 511 keV  $\gamma$ -photons.

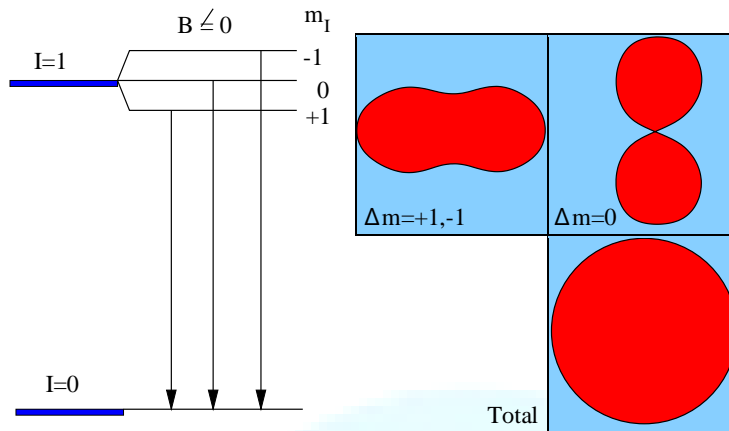

Figure 1: The degenerated energy levels can be separated by a magnetic field. Each component in the decay will then have a specific angular distribution. But if the sub-levels are evenly populated the sum distribution will be isotropic.

## 2 Multipolarity

A discrete state in an atomic nucleus is characterised by (among other things) its parity, and its spin. If we can determine the spin and parity experimentally, we can learn something about the inner structure of the nucleus (using a given model). It is therefore important to find ways of deducing the spin and parity for the different states of the nucleus.

To find information about the different states of a nucleus we study the *transitions* between the states. A transition from one state to a energetically lower state will result in the emission of energy from the nucleus. This energy is usually emitted in the form of a  $\gamma$  photon, but the nucleus can also interact with the electrons of its atom to release the excess energy.

A  $\gamma$  photon emitted from a nucleus will have an energy corresponding to the difference in energy between the initial and final state of the nucleus. The *multipolarity* of the photon corresponds to the angular momentum that the photon carries away from the nucleus. If we know the spin and parity of one of the states, we can learn something about the spin and parity of the other state by measuring the multipolarity of the emitted photon.

The multipolarity of a nuclear transition can be measured in various ways. One striking difference between different multiplicities is the angular intensity distribution of the radiation. The distribution is given by the Legendre polynomials of the corresponding order. The distribution of the radiation for one transition will only give us information about the order of the transition, it is not possible to see if the transition is magnetic or electric. To do this we also need to measure the polarisation of the radiation.

To get a non-isotropic intensity distribution, the magnetic sub-levels must be unevenly populated. Assuming, see figure 1 that an  $I=1$  state is de-excited into an  $I=0$  state, we have three possible transitions corresponding to the three magnetic sublevels for  $I=1$ . Each transition has a different  $\Delta m$ , and therefore a different angular intensity distribution. The problem is that it is not trivial to separate the three transitions. We can split up the levels by applying an external magnetic field, but even a very large field will not make it possible to separate the transitions with a normal  $\gamma$ -ray detector. We will therefore see a sum of the three angular distributions, and if the sub-levels are evenly populated the sum will be isotropic. One way to solve the problem is to lower the temperature of the source so that the Boltzmann distribution will give an uneven distribution of the population of the sub-levels. To do this, the temperature must be as low as about 0.01 K.

We see that there are several difficulties in using the intensity distribution for measuring the multipolarity of a nuclear transition. There are however other ways of solving these difficulties, like using so-called angular correlation measurements (Krane, ch. 10.4).

In this laboratory we will use another technique to measure the multipolarity of a transition. This method does not depend on the angular intensity distribution of the  $\gamma$  radiation. Instead, we use the fact that the relative intensity of internal conversion depends on the multipolarity of the transition (the intensity also depends on other factors, see Krane, page 346). By measuring the internal conversion intensity, we can therefore deduce the multipolarity of the transition.

### 3 Internal Conversion

The internal conversion coefficient is defined as:

$$\alpha_{ik} = \frac{I_e}{I_\gamma}, \quad (3)$$

where  $I_e$  is the intensity of the conversion electrons and  $I_\gamma$  is the intensity of the gamma radiation.  $I_\gamma$  can easily be determined by calculating the area of the corresponding peak in the energy spectrum. To determine the intensity of the conversion electrons we will not measure the electrons directly in this case (for doing this we would need an electron detector). Instead, we will measure the intensity of the X-ray radiation that is sent out when the electron holes (created by sending out the conversion electrons) are filled by electrons from higher lying shells. This intensity must however be corrected to account for the Auger effect, since this process competes with X-ray emission. The ratio between the X-ray intensity  $I_X$  and the intensity of internal conversion  $I_{ik}$  is given as:

$$\eta = \frac{I_X}{I_{ik}}. \quad (4)$$

Diagrams for  $\eta$  can be found in appendix A.

Another problem is that we must compensate for the efficiency of the detector. This efficiency is energy dependent, so an efficiency curve can be plotted

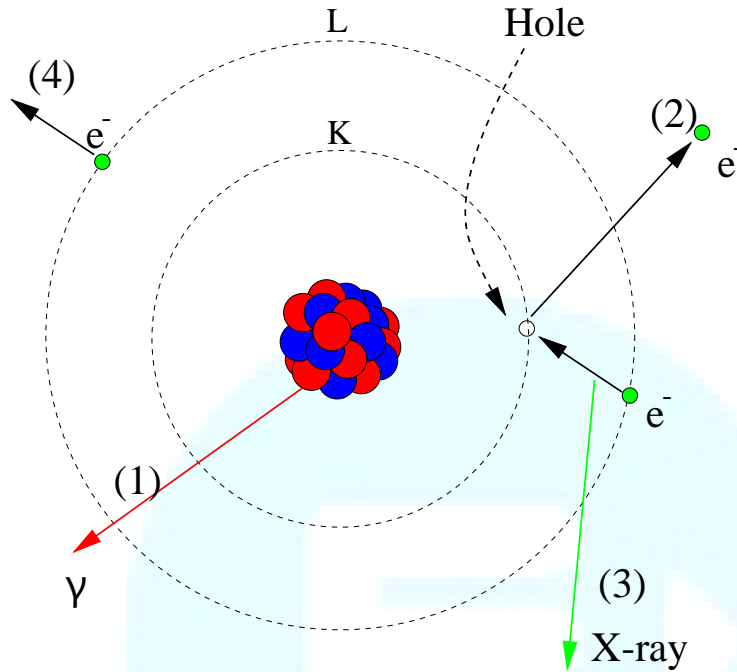

Figure 2: A schematic picture of different ways to de-excite an atomic nucleus. The nucleus can be de-excited by  $\gamma$ -ray emission (1), but also by emitting a closely bound electron from the atom (2). Usually a K-electron is emitted, but an electron in the L-shell (or a higher shell) can also be emitted. The electron hole that appears will soon be filled by another electron. This can result in the emission of an X-ray photon (3), or the emission of an Auger electron (4).

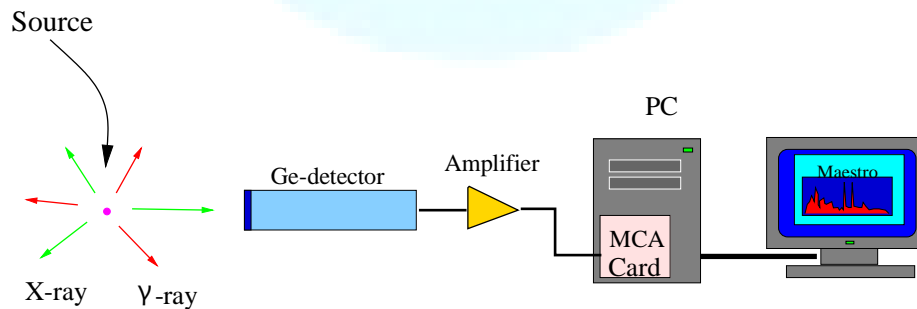

Figure 3: The detector set-up of the present laboration.

by measuring the intensities of some  $\gamma$ -ray peaks for a number of calibration sources. Using the efficiency curve, the ratio between the detector efficiencies for the X-rays and  $\gamma$ -rays of interest can be measured as:

$$\epsilon = \frac{\epsilon_{\gamma}}{\epsilon_X}. \quad (5)$$

By combining the relations above we can now calculate  $\alpha_{ik}$ . Diagrams that relate  $\alpha_{ik}$  to energy and multi-polarity can be found in the laboratory. From this multi-polarity we can conclude the spin and parity for the 662 keV state of  $^{137}\text{Ba}$  by using the selection rules.

## 4 Equipment

A schematic picture of the detector set-up of the present lab exercise is seen in figure 3. A radioactive source is put in front of a germanium detector. The source will emit  $\gamma$ -rays from nuclear de-excitation, and also X-rays that originate from internal conversion. The germanium detector must be cooled to low temperature by liquid nitrogen. The electronic signal from the detector is fed into an amplifier and then to a multi-channel analyser (MCA) that can sort the signal into a large number of energy channels. The **Maestro** PC software is then used to display and analyse the energy spectrum.

## 5 The Laboration

In the present laboration we use a source of  $^{137}\text{Cs}$  to study internal conversion. The  $^{137}\text{Cs}$  nucleus decays by  $\beta$ -decay into two different states in  $^{137}\text{Ba}$  (figure 4). One of these states is the ground state, the other is an excited state, 662 keV above the ground state.

$$7/2^+$$

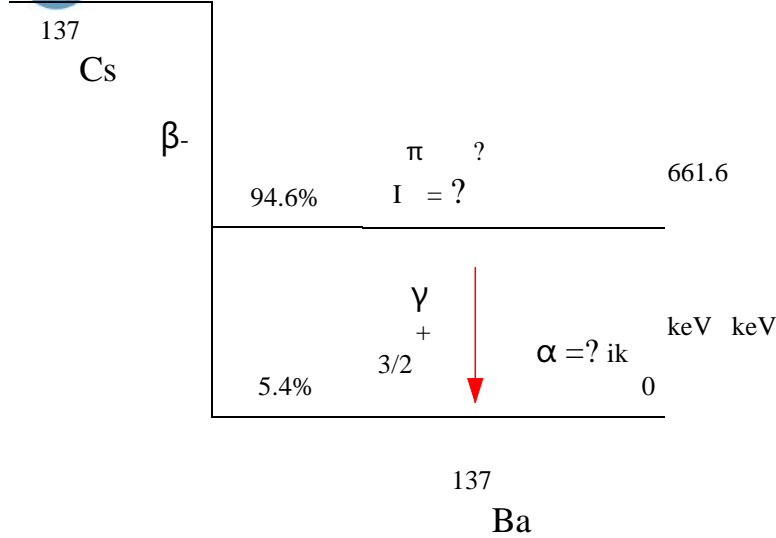

Figure 4: The decay of  $^{137}\text{Cs}$  into two states of  $^{137}\text{Ba}$ . The purpose of the lab. exercise is to determine the spin and parity of the excited 662 keV state of  $^{137}\text{Ba}$ .

### 5.1 Start the ACQ

The MCA PC card is controlled by the **Maestro** software on the PC. Put a source (for example  $^{60}\text{Co}$ ) in front of the NaI detector and start the acquisition system from within **Maestro**. Try to explain what you see in the different parts of the spectrum. Then, do the same thing with the germanium detector. What is the most striking difference between the two detector types?

### 5.2 Energy Calibration

The multichannel analyser (MCA) is not energy calibrated before the lab. exercise. We must therefore use a few of the known energies of the calibration sources to calibrate the MCA.

### 5.3 Efficiency Curve

To determine the conversion coefficient  $\alpha_{ik}$  we must first measure the efficiency of the detector as a function of energy. This is done by using the known intensity for a number of  $\gamma$ -transitions in a few calibration sources. The half-lives and relative gamma intensities are found in table 1.

### 5.4 Determine $\alpha_{ik}$

Now we can determine the conversion coefficient  $\alpha_{ik}$  by using the relations above, using the graphs given in appendix B.

Source	Half-life	$E_\gamma(\text{keV})$	$I_\gamma(\%)$
--------	-----------	------------------------	----------------



<sup>57</sup> Co	271.7 d	14.4	9.2
		122.1	85.6
		136.5	10.7
<sup>241</sup> Am	432 y	26.3	2.4
		59.5	36.0
<sup>133</sup> Ba	10.52 y	81.0	34.1
		276.4	7.1
		302.9	18.3
		356.0	61.9
		383.8	8.9
<sup>22</sup> Na	2.6019 y	1274.5	99.9
<sup>60</sup> Co	5.2714 y	1173.2	99.9
		1332.5	100.0
<sup>152</sup> Eu	13.542 y	121.8	28.4
		244.7	7.5
		344.3	26.6
		411.1	2.2
		444.0	3.1
		778.9	13.0
		867.4	4.2
		964.1	14.6
		1085.8	10.1
		1089.7	1.7
1112.1	13.5		
1212.9	1.4		

		1299.1	1.6
		1408.0	20.8

Table 1: Half-lives, energies, and intensities for a few calibration sources.

## 5.5 Error estimation

In order to have a meaningful and correct interpretation of the extracted result an error estimation is required.

## 5.6 Spin and Parity

The multipolarity for the 662 keV transition can now be determined from a diagram. When we know the multipolarity we can deduce the spin and parity for the 662 keV level in  $^{137}\text{Ba}$  by using the selection rules.

## 6 Questions

Try to answer the following questions before the laboration. These questions will be the basis for a discussion at the beginning of the lab. exercise.

- What is internal conversion?
- How is the internal conversion coefficient defined?
- What parameters does it depend on?
- What is the meaning of the *multipolarity* of a electro-magnetic transition?
- What selection rules are valid for the electro-magnetic transitions?
- Why can there be no M0-transitions?
- How can a E0-transition be realised?
- How does the germanium detector work?
- What is limiting the speed of the germanium detector?
- Why is an alpha-particle stopped faster than a proton when entering materials?
- Electrons are different from the other charged particles when it comes to detection methods. In what way?
- What is the big advantage of the germanium detector over the NaI detector?

- Does the NaI detector have any advantage over the germanium detector?
- What kind of statistics determine both the radioactive decay and the detection process?
- What can be read from the so-called *Bragg curve*?
- What is a *single-escape peak* and what is a *double-escape peak*?

## Appendix A

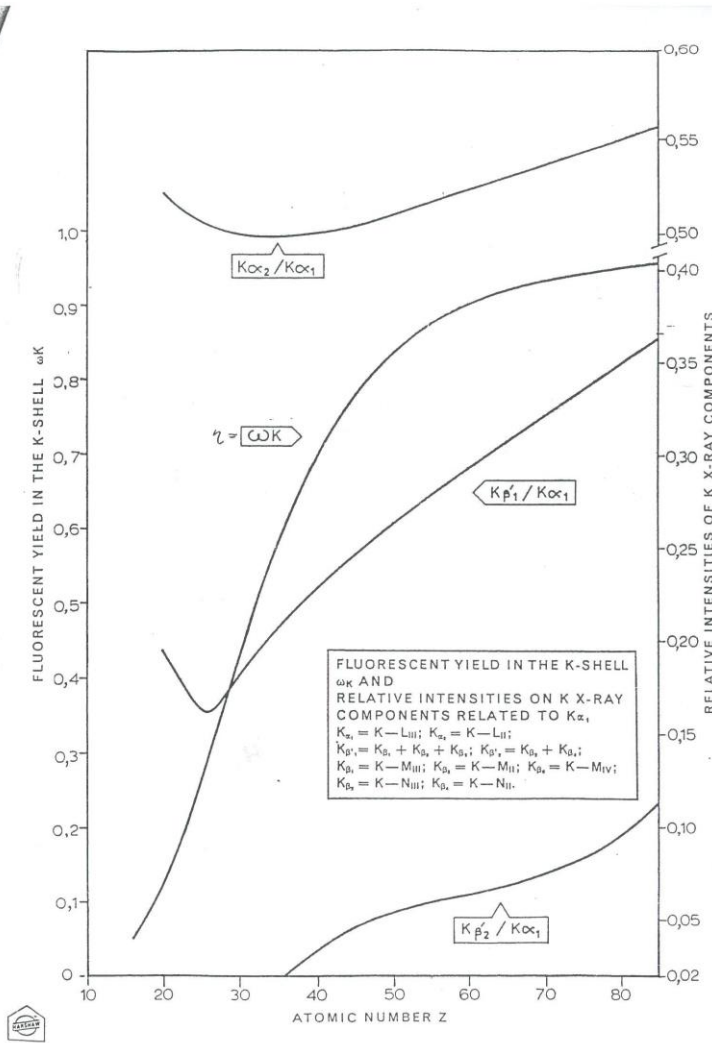

## Appendix B

