

BASICS OF ELECTRON SPIN RESONANCE

(i) INTRODUCTION

Zavoisky in 1945 performed the earliest magnetic resonance experiments in a solid. He observed strong electron spin resonance absorption in several paramagnetic salts. Applications of electron magnetic spin resonance in solid state physics are of great importance. It is a very sensitive technique and has been applied in many fields. The chief of these are :

- (a) Paramagnetic ions in crystals,
- (b) Unpaired electron in semi-conductors and organic free radicals,
- (c) Colour centres, and radiation damage centres, (d) Ferro and anti-ferro magnetic materials.

(ii) ELEMENTARY MAGNETIC RESONANCE

The fundamentals of elementary magnetic resonance may be understood in terms of simple classical concepts. Suppose a particle having a magnetic moment $\vec{\mu}$ is placed in a

uniform magnetic field of intensity H_0 (Fig.1a). Then the moment $\vec{\mu}$ will precess around H_0 with an angular Larmor frequency

$$\omega_0 = g \frac{e \hbar}{2mc} H_0 \quad (1)$$

g being the Lande' g-factor ($g=1$ for pure orbital momentum and $g=2$ for a free electron spin). For the case of anion in a crystal, the behaviour is modified by the environment and the g - factor may differ from the Lande' g-factor. This effective g - factor is known as the spectroscopic splitting factor.

We now introduce an additional weak magnetic field oriented in the xy plane and rotating about the z axis (in the same direction as the "Larmor precessing") with an angular

frequency ω_1 . If the frequency ω_1 is different from ω_0 the angle between the field H_1 and the magnetic moment $\vec{\mu}$ will continuously change so that their interaction will average out to zero.

If, however, $\omega_1 = \omega_0$ the angle between $\vec{\mu}$ and H_1 is maintained and net interaction is effective (Fig.1b). If we look at the system in a reference frame that is rotating about the z axis with the

angular velocity ω_0 then the spin will appear to make an angle $\theta = 90^\circ - \alpha$ with H_1 , and according

to the previous argument will start to precess (in the rotating frame) about H_1 . This corresponds to a "nutation" and a consequent change of the angle which implies a change in the potential energy of the particle in the magnetic field. The change in μ_z is the classical analogy to a

transition between sublevels with different m . We see that such transitions may take place only if the rotating field has an angular frequency $\omega_1 = \omega_0$.

Let us proceed to consider the quantum picture of elementary magnetic resonance.

Suppose that the intrinsic angular momentum of the electron \vec{S} couples with the orbital

angular momentum of electron \vec{L} to give a resultant \vec{J} . We know, that $J+1$ magnetic sublevels labelled by the magnetic field H_0 by equal energy difference,

$$\Delta E = g \mu_B H_0$$

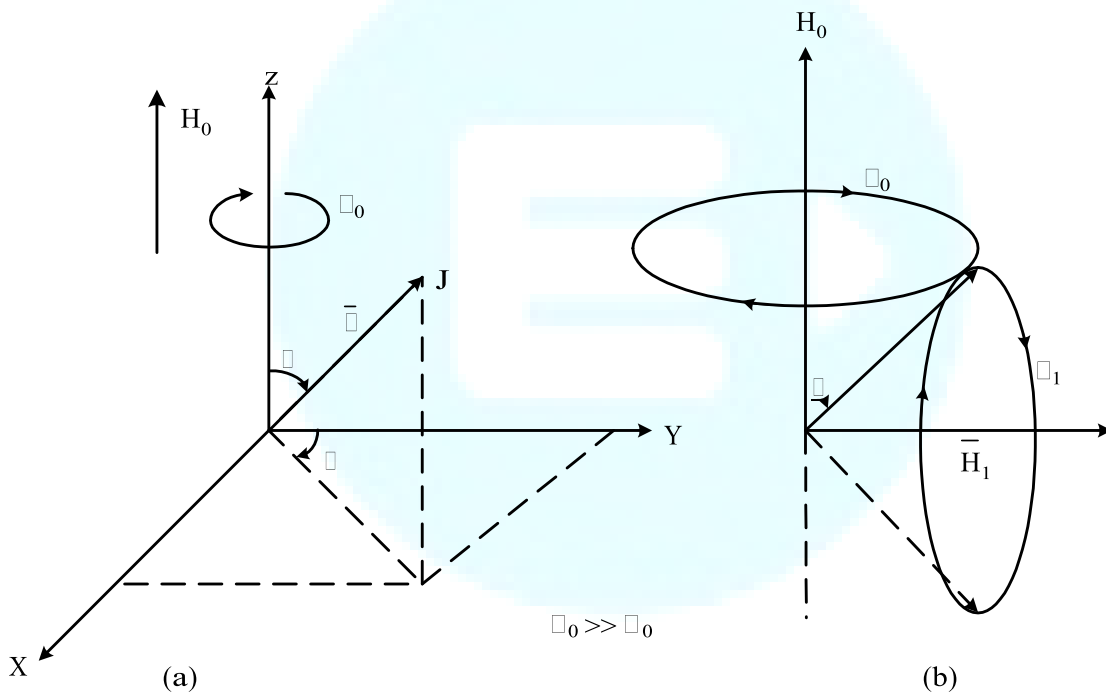

Fig. 1 : Precession of a magnetic moment \vec{J} when placed in a magnetic field H_0

(a). The spin precesses with angular frequency $\omega_0 = \gamma H_0$; the angle θ is a constant of the motion.

(b). In addition to H_0 a weak magnetic field H_1 is now also applied. H_1 is rotating about the z axis with angular frequency ω_1 and therefore $\omega_0 \gg \omega_1$

precesses about H_1 with angular frequency $\omega_1 = \omega H_1$; ω is not any more conserved.

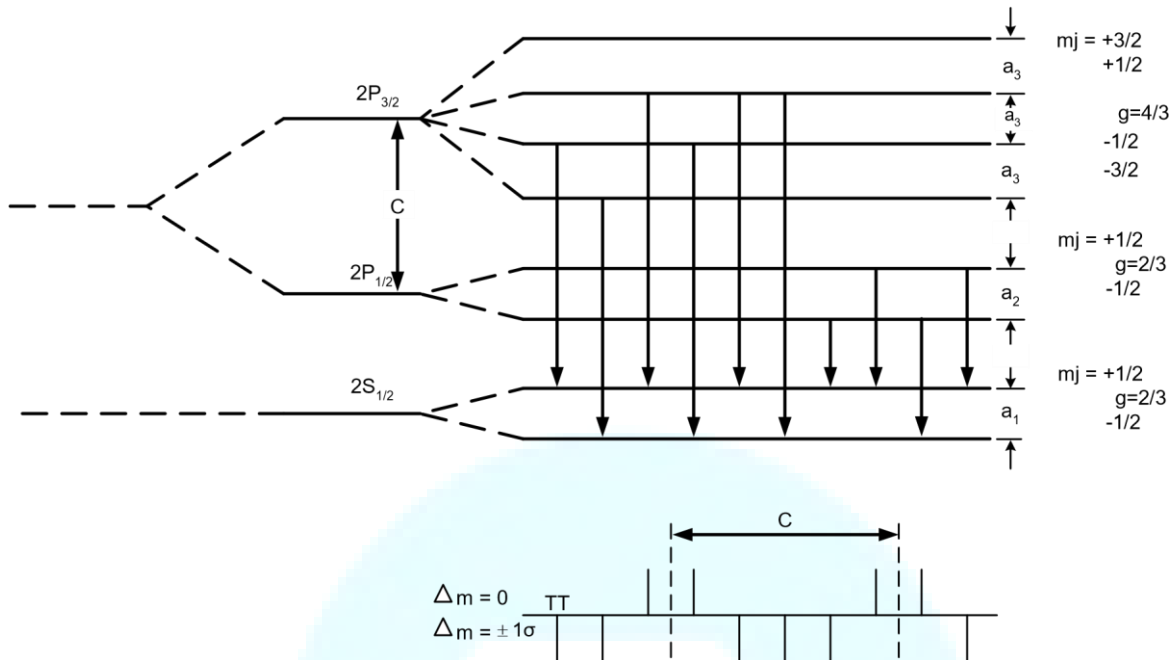

Fig. 2 : Energy levels of a single valence electron atom showing a P state and an S state. Due to the fine structure, the P state is split into a doublet with $j=2/3$ and $j = 1/2$. Further, under the influence of an external magnetic field each of the three levels is split into sublevels as shown in the figure where account has been taken of the magnetic moment of the electron. The magnetic quantum number m_i for each sublevel is also shown as is the g factor for each level. The arrows indicate the allowed transitions between the initial and final states, and the structure of the line is shown in the lower part of the figure.

between adjacent sublevels, where μ_0 is the Bohr magnetron and g is the Lande' factor or g factor whose correct quantum mechanical value is

$$g = \frac{J(J+1) + S(S+1) - L(L+1)}{2J(J+1)}$$

Now, if the particle is subjected to a perturbation by an alternating magnetic field with a frequency ω_1 such that the quantum $h\omega_1$ is exactly the same as the difference between the levels, ΔE and if the direction of the alternating field is perpendicular to the direction of the static

magnetic field, then there will be induced transitions between neighbouring sublevels according to the selection rules $\Delta m = \pm 1$ for magnetic dipolar radiation.

Therefore, the condition for resonance is

$$\hbar E = g\mu_0 H_0 = \hbar\nu_0 = \hbar\nu_1 \quad (2)$$

Where ν_1 is the resonance frequency in cycles/sec. This requirement is identical with the classical condition $\nu_1 = \nu_0$.

In atomic spectroscopy, we do not observe the transitions between sublevels with different m (labelled a , a and selection rules $\Delta L = \pm 1$. Instead the splitting of a level is observed through small change in frequency of the radiation emitted in the transition between widely distant levels (Fig.2). It is clear that, if we could directly measure the frequency corresponding to a transition between the sublevels of the same state, a much more precise knowledge of the energy splitting would be obtained.

(iii) ELECTRON SPIN RESONANCE IN SOLIDS

Let us proceed from the treatment of an isolated magnetic particle to a macroscopic body. The behaviour of a paramagnetic substance in a magnetic field will depend on the interaction of the particles with one another and with the diamagnetic particles. There are mainly two types of interactions.

- (a) Spin - Spin: In which the spin interacts with a neighbouring spin but the total energy of the spin system remains constant.
- (b) Spin - Lattice: In which the electron spin interact with entire solid or liquid, transforming energy from the spin system to the lattice which act as a thermal reservoir. As a matter of fact it is the spin-lattice interaction that makes possible the observation of energy absorption from the radio- frequency field when the resonance frequency is reached.

To understand this last statement, consider a paramagnetic substance in a magnetic field

H_0 and say the equilibrium state has been reached. The population of individual energy levels will be determined by the Boltzmann distribution $e^{-g\mu_0 H_0 m / kT}$ where m is the magnetic quantum number. It can be seen that the population of the lower energy levels are greater than those of the upper levels and, therefore when a periodic magnetic field with a resonance frequency is switched on; the number of induced radiation events will be more and as a result the substance will absorb energy from the radio-frequency field. Thus, two opposing processes take place in ESR. The radio frequency field tends to equalise the population of various levels and the spin lattice interaction tends to restore the Boltzmann distribution by conversion of the energy absorbed from the radio-frequency field into heat.

(iv) RELAXATION AND SATURATION

In the preceding para, we see the mechanism through which the electron return from an excited state to the ground state or relax back to the ground state. This process in the field of magnetic resonance's (ESR, NMR, NQR ETC.) is know as relaxation and the time taken by the process is called the relaxation time. This complete process may be considered as two state process (provided the spin-spin interactions are much stronger than the spin-lattice interaction).

First, the energy is absorbed from the radio frequency magnetic field and the equilibrium is established inside the 'spin system'. The time taken by this process is known as the spin-spin relaxation time and is a measure of the rate at which magnetic energy can be distributed within the spin system though total energy is conserved. Secondly, an exchange of energy occurs between the spin system and the lattice. The time taken is known as the spin lattice relaxation time and is a measure of the rate of transfer of energy from the spin system to the lattice.

In optical spectroscopy of the relaxation time is usually very short ($\sim 10^{-8}$ sec) so that the relaxation time does not impede the absorption rate. In radio frequency, on the other hand, typical relaxation times are in milliseconds or longer and the spin do not have time to relax if the energy is supplied at a faster rate. This situation is called the 'Saturation State'. In other words, no additional energy is absorbed, if the radio- frequency field power is increased beyond certain level.

(v) LINE WIDTH AND THE SPIN-SPIN AND SPIN-LATTICE INTERACTIONS

The effect of the spin-spin interaction is to slightly shift the exact position of energy level of any individual spin in the external field. This energy shift clearly depend on the relative orientation and distance of the spin and thus is different for each spin, resulting in apparent broadening of the energy level. Another way of thinking of the spin-spin interaction is that one electron spin produce a local magnetic field at the position of another spin. Thus,

the width of absorption line due to spin-spin interaction may be estimated as $\frac{1}{T'}$, where T' is spin-spin relaxation time.

If the spin-lattice interactions are not weak the spin lattice relaxation time T will also be introduced. Let us consider the probability of a transition of an individual paramagnetic particle from one magnetic level to another under the influence of thermal motion. If the probability per second equal A , $T \sim \frac{1}{A}$ and the absorption line width would be of the order

$\frac{1}{T} + \frac{1}{T'}$ of $\frac{1}{T}$. In general case, however, the absorption line width may be estimated as $\frac{1}{T} + \frac{1}{T'}$.

Thus, we see that from the width of absorption line it is possible to measure the relaxation time. In fact most of the research in this field involve the study of relaxation phenomena which in turn provide information about internal interactions in solids and liquids.

The position and number of lines of paramagnetic resonance absorption also depend on the internal interactions.

(vi) ELECTRON PARAMAGNETIC RESONANCE AND SPECTROSCOPY

Paramagnetic resonance is an integral part of spectroscopy, as it provides a means for determining the position of the energy levels of magnetic particles. It is interesting to consider the peculiar features of Paramagnetic resonance in comparison with optical spectroscopy.

1. Let us first note that the frequencies used in magnetic resonance experiments range from 10^9 to 10^{11} cps. These frequencies situated below the limits of the infrared part of the

spectrum, allow highly accurate investigation of energy level splitting so small that they are inaccessible or almost inaccessible by optical methods.

2. The probability of spontaneous transition in the radio-frequency region is very small, since this probability is proportional to ν^3 . Therefore, in paramagnetic resonance studies one is forced to deal only with induced absorption and emission.
3. While in the great majority of cases optical spectra arise from electric dipole transitions between energy levels, the lines of paramagnetic resonance absorption arise exclusively from magnetic dipole transitions. Consequently, the Einstein coefficients for induced absorption and emission will, in the case of paramagnetic resonance, be smaller by roughly four orders of magnitude.
4. As a result, the paramagnetic resonance effect is exceedingly small; if it can be observed at all is due to the high sensitivity of electronic methods of detection and the enormous number of photons coming into play (1mW corresponds to $n \approx 10^{20}$ photons per sec at a frequency of 10^{10} cps).
5. In the optical frequency region the line width is always very small in comparison with the fundamental frequency. In paramagnetic resonance the relation between these quantities becomes quite different, since the interactions causing a broadening of the lines can be of the same order of magnitude as the energy splitting which determines the resonance frequency. Because of this the width of paramagnetic resonance lines is often comparable to the fundamental frequency and can be measured with great accuracy. This opens up wide possibilities for investigation of different types of interactions in paramagnetic substances by means of analysis of the shape and width of a paramagnetic resonance line and of the character of its dependence upon various factors.
6. The most important factors determining the line width are magnetic dipole interactions, exchange forces, local electrical fields created by neighbouring magnetic particles, and finally, thermal motion; the natural line widths of radio- frequency spectra are completely negligible.
7. In contrast with optical experiments, in radio-frequency spectroscopy it is customary to use radiation which is so monochromatic that the generated band of frequencies is incomparably narrower than the absorption line width.
8. Paramagnetic resonance spectra are not studied by varying the frequency of the incident radiation, but by varying the characteristic frequencies of the absorbing systems. This is achieved by varying the static magnetic field.

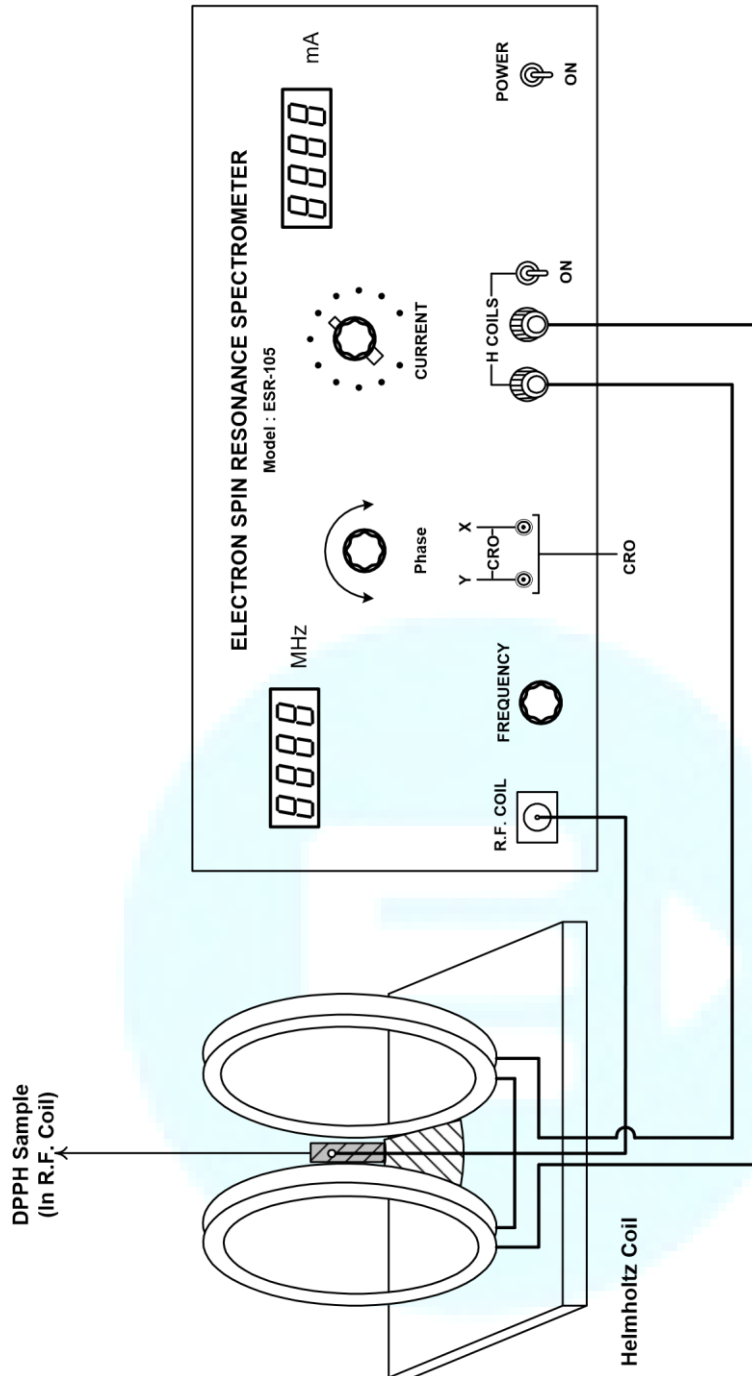

Panel Diagram of Electron Spin Resonance Spectrometer, ESR-105

(vii) GENERAL CONSIDERATIONS

For a free electron, by substituting the proper values of constants : $g=2.00$, $\mu_0=0.927 \times 10^{-20}$ erg / Gauss and $h=6.625 \times 10^{-27}$ erg.sec. in equation (2), we get,

$$\frac{\mu_0}{h} = 2.8 \text{ MHz/Gauss } H_0$$

That is ESR can be observed at radio frequencies in a magnetic field of few gauss or otherwise in the microwave region in a magnetic field of a few kilogauss. The latter alternate has many distinct advantages :

- (a) For each transition the absorbed energy is much larger, and thus the signal-to-noise ratio is much improved.

- (b) A high magnetic field is used, thus providing separation between levels that are intrinsically wide and would remain partially overlapped at low fields.

Because of these advantages, ESR in microwave region is preferred for research purpose, though, it is very sophisticated and expensive.

The former is preferable, where simplicity, easy operation and cost factor are the main considerations and no high resolution is required ideal for postgraduate level experiments.

(viii) EXPERIMENTAL TECHNIQUES

In the radio frequency region, two types of methods are chiefly used:

1. The method of reaction on the generator
2. The method based on a determination of the change in a load factor of the oscillatory circuit due to paramagnetic loss.

The latter method has been used here. The sample under investigation is placed in an induction coil, which is the component of the tank circuit of the oscillator (generator). This is the Zavoisky's technique. It is based on the fact that under certain conditions such as absorption of power from generator, the watt load (Δw) on the generator changes. This change of Δw is proportional to the change in base current ΔI_b or collector current ΔI_c of the generator. The proportionality, however, holds only the power dissipated by the sample due to paramagnetic absorption is small in comparison to the total losses in the circuit. This change in ΔI_c is detected with the conventional circuits. To make the detection simple and more sensitive, the magnetic field and hence the Larmor frequency of the sample is modulated with a low frequency field 50Hz in the present set-up.

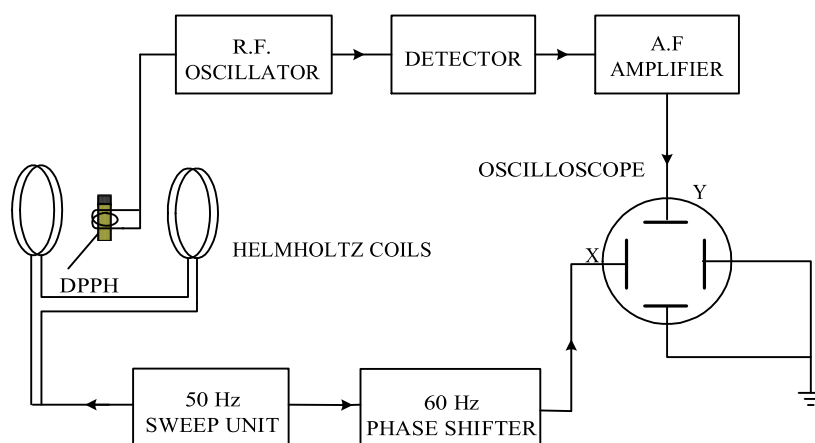

Fig. 3 : Block Diagram of the ESR Set

DESCRIPTION OF THE ESR SPECTROMETER

A block diagram of the ESR Spectrometer is given in Fig. 3 and panel diagram on the previous page.

1. **Basic Circuit:** The first stage of the ESR circuit consists of a critically adjusted (marginal) radio frequency oscillator having a frequency range of approximately 12–16MHz. A marginal oscillator is required here so that the slightest increase in its load decreases the amplitude of oscillation to an appreciable extent. The sample is kept inside the tank coil of this oscillator, which in turn, is placed in the 50Hz magnetic field, generated by the Helmholtz coils. At resonance, i.e. when the frequency of oscillation equal to the Larmor's frequency of the sample, the oscillator amplitude registers a dip due to the absorption of power by the sample. This obviously, occurs periodically - four times in each complete cycle of the Helmholtz coils supply voltage. The result is in amplitude modulated carrier (Fig. 4A) which is then detected using a diode detector and amplified by a chain of three low noise, high gain audio - frequency amplifiers of excellent stability. A sensitivity control is provided in the amplifier to suit the input requirement of any oscilloscope.
2. **Phase Shifter:** In order to make it possible to use an ordinary displaying type oscilloscope, instead of a measuring oscilloscope which preserve the phase between X and Y plates signals, a phase shifter is provided. This can compensate the phase difference which is introduced in the amplification stage of the ordinary oscilloscope.

The circuit diagram of the phase shifter is shown in Fig. 4B. The primary of the transformer is fed from the 220V, 50Hz (or 110V, 60Hz) mains and the secondary is centre tapped developing V_1 -0- V_1 (say). The operation of the circuit may be explained with the help of the vector diagram shown in Fig. (4B). The vectors OA and BO represent the voltage developed in the secondary, in phase and magnitude. The current flowing in the circuit ADB leads the voltage vector BA due to the presence of capacitor C and is shown in the diagram as I. Voltage developed across resistance R, i.e. V_R is in phase with the current I, and the voltage across across capacitor V_c is 90° (lag) out of phase with the current. The vector sum of V_c and V_R is equal to $2V_1$. These are also plotted in the diagram. It is clear from the diagram that as R is varied, V_R will change and the point D will trace a semicircle, shown dotted. The vector OD, or the voltage across points 0 and D, will, therefore, have a constant magnitude equal to V_1 and its phase, variable from 0 to 180° . This is the voltage which is fed to the X-amplifier of the oscilloscope to correct for any phase change which might have taken place in the rest of the circuit.

3. **50 Hz Sweep Unit :** For modulation with a low frequency magnetic field, a 50 Hz current flows through the helmholtz coils. As the resonance in this frequency range occurs at low magnetic fields, no static D.C. magnetic field is required.
4. **Power Supplies :**
 - a) **D.C. Power Supply :** The ESR circuit requires a highly stabilised almost ripple free voltage. These are obtained using integrated circuit regulator.
 - b) **Helmholtz Coils Power Supply :** The Helmholtz coils power supply consists of a step down transformer (220 to 35 V AC). Variable coil current is provided in 10 steps using

ENTRI

a band switch, while the current is displayed on a 3 ½ digit panel meter. The output is taken from the two terminals provided on the panel.



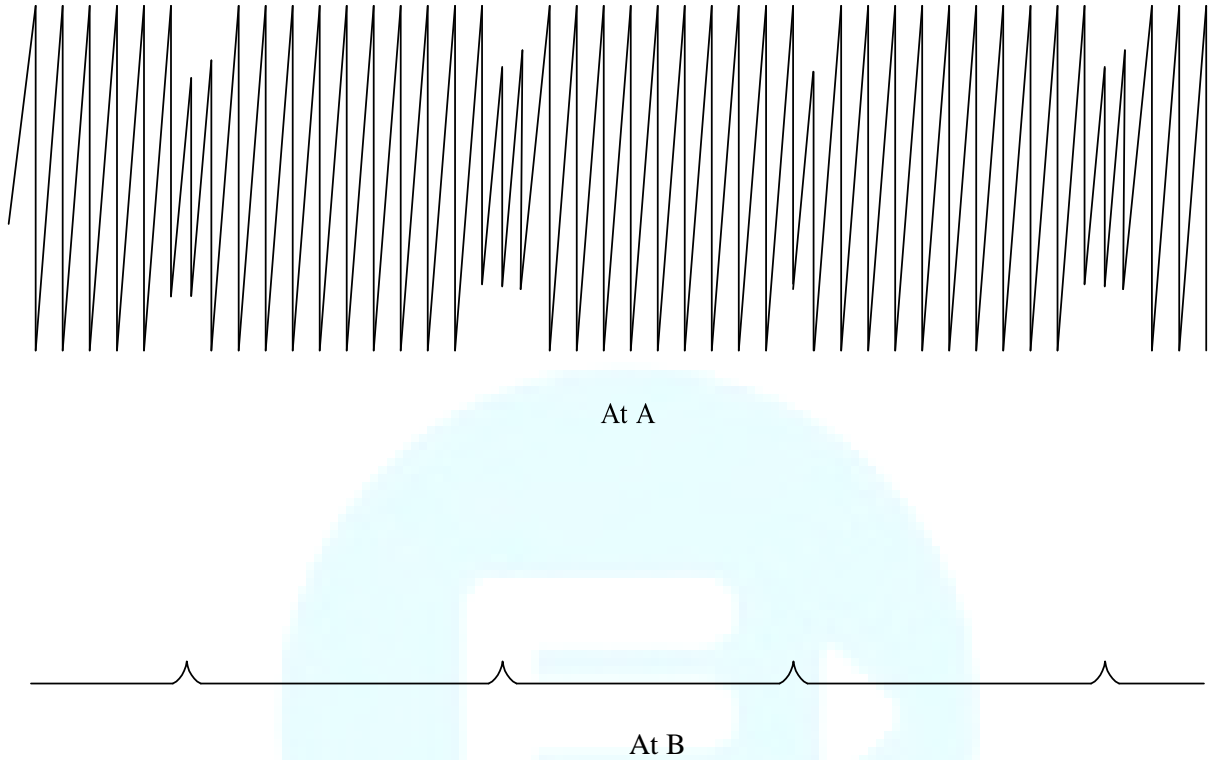

Fig. 4 (A)

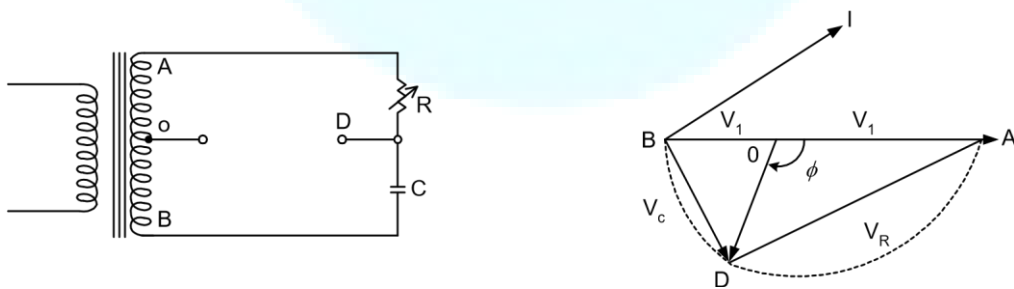

Fig. 4 (B)

5. Helmholtz Coils : There are two coils exactly alike and parallel to each other, so connected that current passes through them in the same direction. The two coils increase the uniformity of the field near the centre.

Number of turns	:	500 in each coil
-----------------	---	------------------

Diameter of the Windings	:	15.4 cm
Separation of the coil	:	7.7 cm

In the centre of the coils, an attachment is provided to keep the sample in place and to minimise shocks and vibrations.

6. **Test Sample:** A test sample, Diphenyl Picryl Hydrazyl (DPPH) (Fig. 5) is placed in a plastic tube, which itself is in the induction coils. This increases the filling factor to the maximum. DPPH is a free radical and widely used as a standard for ESR measurements.
8. **Controls & Terminals :** (Please refer to Panel Diagram)
 - (1) Mains : To switch 'ON' or 'OFF' the ESR Spectrometer.
 - (2) Phase : To adjust the phase between X and Y plates signals.
 - (3) Current : To control current in Helmholtz coils.
 - (4) 'H' Coils : Terminals and switch for Helmholtz coils.
 - (5) Frequency : To adjust the frequency of the Oscillator.
 - (6) X,Y,E : For X, Y and Earth terminals of the Oscilloscope.
9. **Oscilloscope:** Any Oscilloscope, normally available in the laboratory of the following specifications or better, will be quite suitable for the observation of ESR resonance :

Screen diameter : 12.5 cm
Vertical amplifier sensitivity : 50 mV/cm

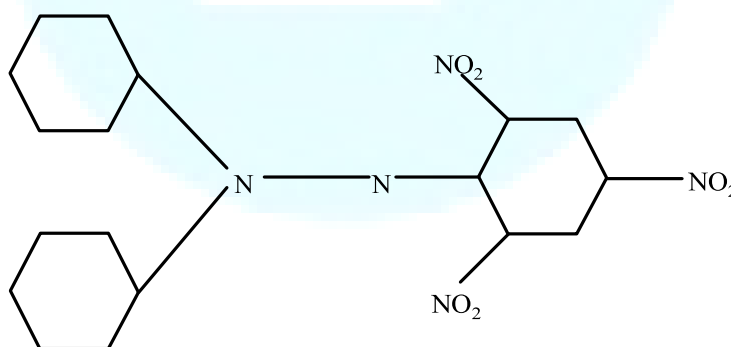

Fig 5.: Chemical structure of DPPH (2,2-Diphenyl-1-picrylhydrazyl, (free radical, 95%))

OPERATING INSTRUCTIONS

(i) OPERATION

- (1) Switch on 'H. COIL' power and adjust the current at 150 mA.
- (2) Set the front panel controls of ESR Spectrometer as follows
Frequency : Centred

Phase : Centred

- (3) Observe four peaks on the Screen of CRO. Now adjust the FREQUENCY of the Spectrometer and SENSITIVITY of the CRO to obtain the best results (i.e. sharp peaks and good signal to noise ratio).
- (4) Adjust the PHASE knob to coincide the two peaks with the other two as far as possible.
- (5) Adjust the orientation of Helmholtz coils with respect to the main unit for best overlap of base lines.

(ii) ORIGIN OF FOUR PEAKS

The observed peaks are in fact absorption dips, because the sample absorb power from the induction coil, reasons explained in Chapter 1. The reason for getting peaks is due to odd number of amplifying stages in the circuitry.

The spin precesses with Larmor's frequency ($\omega_0 = \frac{eH^0}{\hbar}$) and hence varies in magnitude and direction due to variation of magnetic field H_0 which is due to an alternating current in the Helmholtz coils. Now if the radio frequency field, ω_1 falls in the range of ω_0 the resonance occurs. The positions of the four peaks can be understood with Fig. (3).

If the X plate signal (50Hz) and Y plate signal (ESR output) are in phase the I and II peaks and III and IV peaks will coincide. The coincidence of peaks on the x-scale needs to be calibrated for magnetic field measurements. The coincidence ensures that the magnetic field is zero at the centre and has the peak values at the two ends. Complete merger of the peaks on y-scale may not occur due to many reasons such as 50Hz pick-ups, ripples in the power supply etc. Though, every effort has been made to minimise these factors but the large amplification ($\times 4000$) in the circuitry make them substantial. However, any non-coincidence on the y-scale is immaterial as neither any measurement of the y-scale is involved in the calculation of g-factor nor any measurement is made on it.

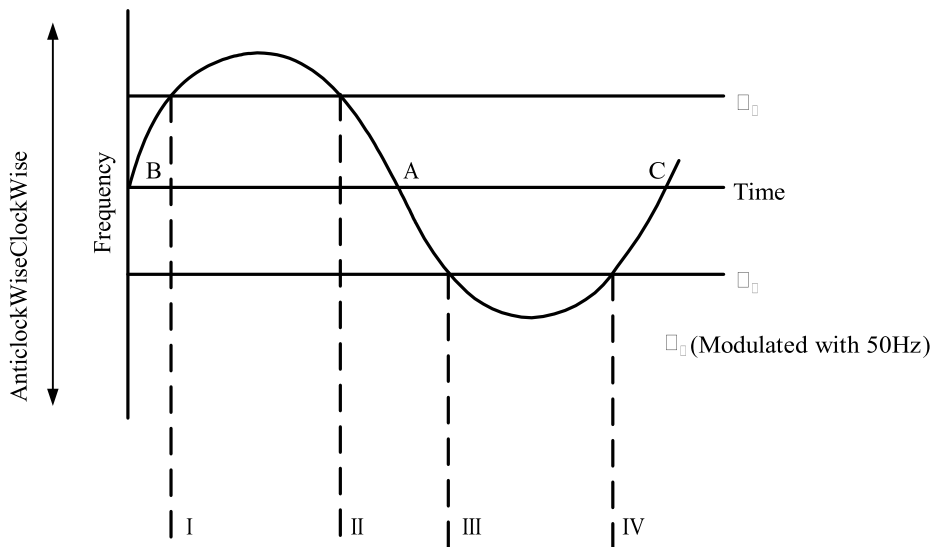

Fig. 6 : The radio frequency is linear by polarised, which can be regarded as two circularly polarised fields of opposite direction (say clockwise and anti clockwise). Further magnetic field H_0 also changes direction. Thus resonance occurs when the two frequencies (ω_1 and ω_0) becomes equal in magnitude as well as direction i.e. four times in one full cycle of H_0 .

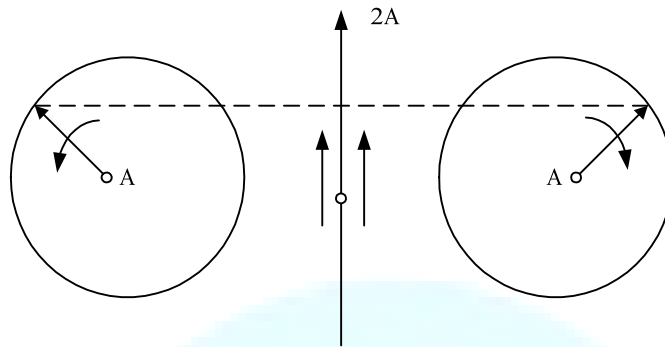

Fig. 6 : A linearly field of frequency is equivalent to two fields rotating in opposite direction with the same frequency ω

(iii) DETERMINATION OF MAGNETIC FIELD

To calibrate the X-plate of CRO in terms of magnetic field proceed as follows :

1. Adjust the X amplifier (CRO) to obtain the maximum X deflection (say 'P' divisions).
2. Read current flowing in Helmholtz coils and calculate the magnetic field.

$$H = \frac{32 \pi n}{\sqrt{10125}} \cdot a$$

Where 'n' is the number of turns in each coil

'a' is the radius of the coils

'I' is the current (in amp) flowing through the coils.

This is the root mean square (rms) field. The peak to peak field will be $2\sqrt{2} \cdot H$ and represents 'P' division of the CRO X plate. The zero field is at the middle point.

3. Measure the positions of the two peaks. These should be at equal distances from the middle point (say "Q' division).The magnetic field at the resonance is thus

$$H_0 = \frac{2\sqrt{2} \cdot H}{P} \cdot Q \text{ gauss}$$