

---

# Semiconductor Lasers

---



## **Contents**

<b>1 Introduction</b>	2
<b>2 Basic Laser Theory</b>	3
2.1 Stimulated Emission	3
2.2 Population Inversion [4]	4

2.3 Physical Structure	5
<b>3 Semiconductor Lasers</b>	<b>7</b>
3.1 Basic Physics	7
3.2 Homojunction Laser [17]	9
3.3 Heterojunction Laser	11
<b>4 Semiconductor Laser Materials</b>	<b>14</b>
<b>5 Applications</b>	<b>16</b>
<b>6 Recent Development: Quantum Dot Lasers</b>	<b>18</b>
<b>7 Future Aspects</b>	<b>21</b>

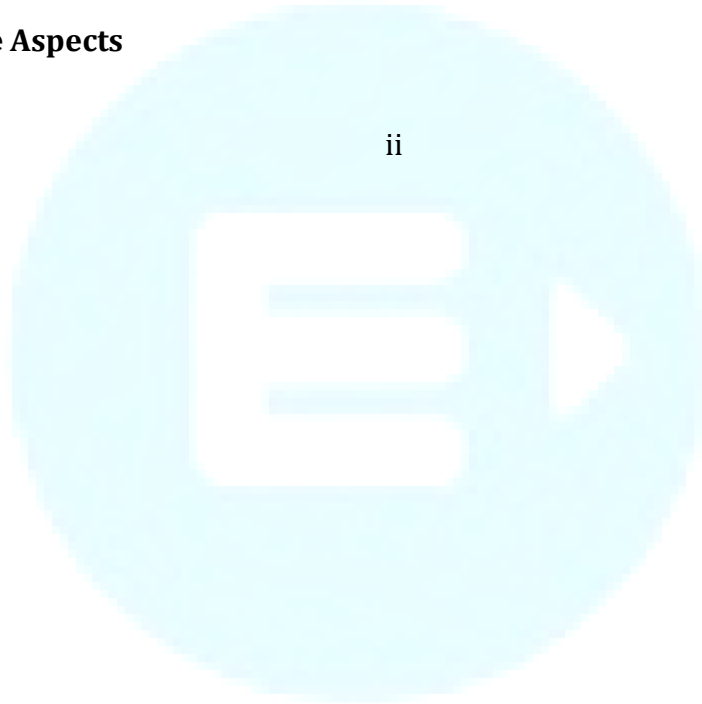



## 1 Introduction

A laser is an optical device that creates and amplifies a narrow and intense beam of coherent, monochromatic light. LASER stands for “Light Amplification by Stimulated Emission of Radiation” [7, 14].

The invention of the laser can be dated to the year 1958, with the publication of the scientific paper *Infrared and Optical Masers*, by Arthur L. Schawlow and Charles H. Townes in the American Physical Society’s *Physical Review* [7]. However, it was Albert Einstein who first proposed the theory of “Stimulated Emission” already in 1917, which is the process that lasers are based on [16].

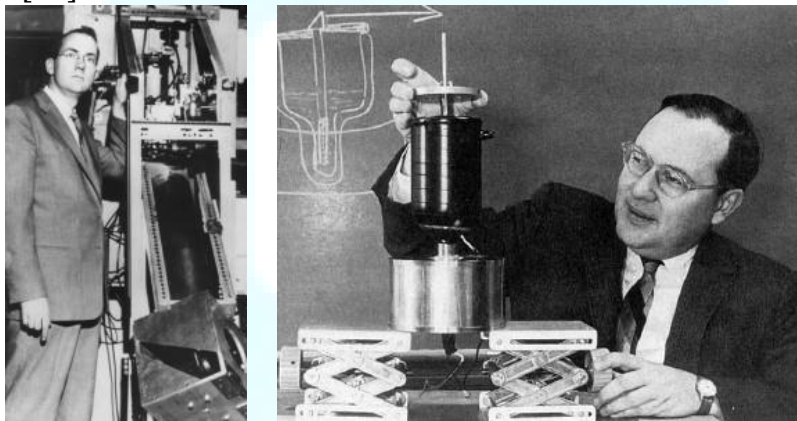

(a) Charles H. Townes (b) Arthur L. Schawlow with a ruby laser, 1961

Semiconductors can be used as small, highly efficient photon sources in lasers. These are called semiconductor lasers [13].

The original concepts of semiconductor lasers dates from 1961, when Basov et al. [2] suggested that emission of photons could be produced in semiconductors by the recombination of carriers injected across a p-n junction. The first p-n junction lasers were built in GaAs (infrared) [3] and GaAsP (visible) [5] in 1962, and this made the laser an important part of semiconductor device technology [14].

Today lasers are used in many different areas such as communication, industry, medicine, and environmental care and research. The laser has

become one of the most powerful tools for scientists in physics, chemistry, biology and medicine throughout the world [16]. The semiconductor laser has become especially attractive because of its low price and small size. It is also very efficient, in contrast to most other laser types, and has very simple power supply requirements [4].

## 2 Basic Laser Theory

### 2.1 Stimulated Emission

The principles of a laser can be explained on the basis of photons and atomic energy levels. For simplicity we consider an atomic electron with only two energy levels separated by an energy  $E$ . When in the lower energy state, the system may be excited to the upper state by absorbing a photon with energy  $E = h\nu$ , where  $h$  is Planck's constant and  $\nu$  is the frequency of the photon. The same atom will later return to the ground level emitting a photon with the same frequency as the one originally absorbed. This process is called *spontaneous emission* and will produce light of random direction and phase [23].

Lasers are based on the process of *stimulated emission*. In this process an electron in a higher or excited state is induced to drop to a lower energy level, stimulated by the presence of photons of the proper wavelength. This drop results in an emission of a photon. The stimulating photons have an energy of  $h\nu$ , the same as the energy difference between the two energy levels. Thus the radiation will be monochromatic, since all the photons will have the same energy. It will also be coherent, because all photons released will be in phase and reinforcing. The process is illustrated in figure 1 [14].

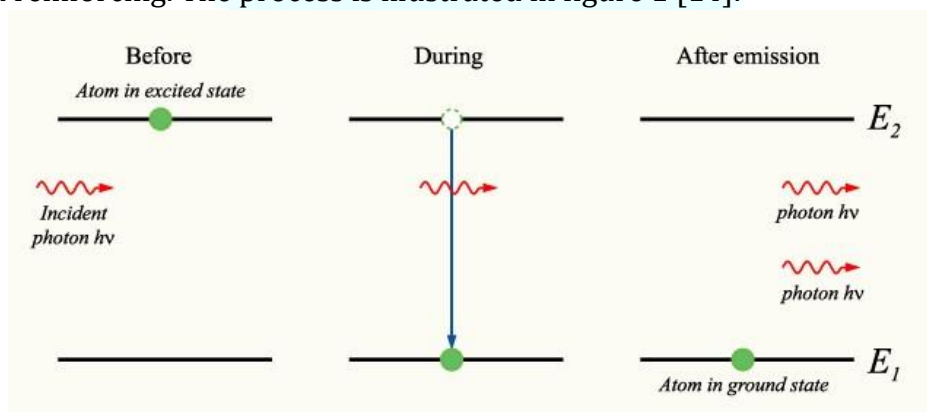

Figure 1: Process of stimulated emission [20].

## 2.2 Population Inversion [4]

Let us assume a collection of atoms where each atom has two energy states  $E_1$  and  $E_2$ . The number of atoms in each state are  $N_1$  and  $N_2$  respectively. If a beam of radiation with frequency  $\nu_{12} = (E_2 - E_1)/h$  is passed through this

### 2.2 Population Inversion [4]

collection of atoms then both absorption and stimulated emission processes occur. The probability of a photon being absorbed when it encounters an atom in the lower energy state, is the same as the photon causing stimulated emission when it encounters an atom in the upper energy state. This means that the photons in the beam will be lost through absorption at a rate proportional to  $N_1$ , and created through stimulated emission at a rate proportional to  $N_2$ . The number of photons,  $n$ , will change in time according to

$$\frac{dn}{dt} = C(N_2 - N_1) \quad (1)$$

where  $C$  is a constant.

When  $N_2 > N_1$  the number of photons will grow in time and laser light is produced. This condition is called *population inversion*. Unfortunately, when atoms are in thermal equilibrium,  $N_1$  is always greater than  $N_2$ , and input of external energy, often called 'pumping', is needed to achieve population inversion.

Consider an example of a three level laser. It consists of a gain medium of ruby formed as a rod and a high power flash tube providing illumination for pumping. Ruby is actually a crystal of  $Al_2O_3$  containing a small amount of  $Cr$ . It is the excitation levels of the chromium that provides the states needed for lasing. Figure 2 shows a schematic diagram of the three levels used for lasing. Levels 1 and 2 are sufficiently far above the ground state so that, in thermal equilibrium, their populations are negligible compared with that of the ground state.

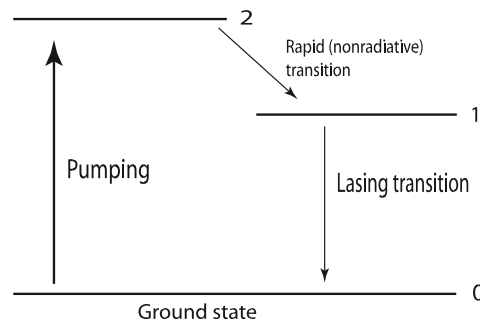

Figure 2: A schematic diagram of a three level laser showing the pumping and laser transitions.

The illumination for the pumping contains the frequency component needed to excite the atoms from level 0 to 2. The atoms in level 2 make

### 2.3 Physical Structure

a rapid (nonradiative) transition to level 1, which has a comparatively long lifetime. The atoms tend to pile up in level 1 and given sufficiently intense pumping, a population inversion between level 1 and 0 is created. Any light of the correct frequency will cause stimulated emission between these two levels, and laser light is created.

### 2.3 Physical Structure

A laser will normally consist of a gain medium with mirrors on each end (see figure 3), and some kind of external energy for pumping. The gain medium can be a solid, liquid or gas, and the beam of photons will amplify as it moves through it. Unless the pumping is extremely intense or the gain medium is very long, the beam irradiance will not be particularly strong after just one transit of the laser medium. This is why mirrors are used in each end to create *optical feedback*. This causes each photon to pass through the medium several times, stimulating more emissions before escaping [4].

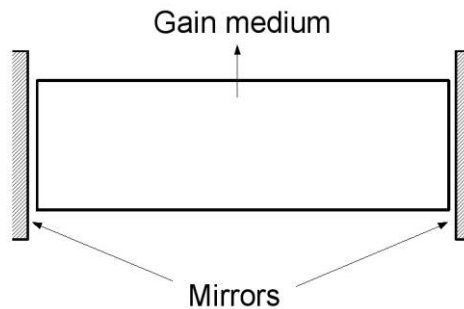

Figure 3: A laser with a gain medium and mirrors on each side to provide optical feedback.

The mirrors and the space between is called *laser cavity* (also called optical cavity). One of the mirrors is usually highly reflective while the other one will have a reflectance of around 95%, allowing the laser light to go through. One of the requirements for stable behaviour for a plane wavefront travelling back and forth within the cavity, is that the phase of the wavefront at a particular point must be the same (to within an integer multiple of  $2\pi$ ). That is why the laser is sometimes more accurately referred to as *laser oscillator* [4].

Several different methods are used for laser pumping, and optical, electrical and chemical pumping are some of the common ones. The intensity of the energy source must be higher than a certain threshold value to be able to

### 2.3 Physical Structure

provide enough excited atoms to exceed the ones lost by spontaneous emission and other factors. Even with high enough pumping the laser beam will not amplify indefinitely. As the irradiance in the cavity increases, the gain tend to decrease because of a reduction in the population inversion. There will inevitable be a cavity loss due to absorption and optical elements which couple light out of the cavity. The irradiance reaches a saturation level when the losses per transit is equal to the gain per transit [4, 18].



## 3 Semiconductor Lasers

### 3.1 Basic Physics

In a semiconductor laser, the gain medium consists of layers of doped semiconducting material. Light is emitted at a junction between two regions of opposite doping as shown in figure 4. The mode of operation is somewhat different than that of the laser described in the previous chapter. In stead of exciting atomic electrons at separate locations in a medium by flashing light, the population inversion is created in the large number of electrons at a junction. And pumping is done by injecting carriers (electrons). Due to the crystalline nature of semiconductors, the electrons do not have discrete energy levels as the single chromium ions in a ruby, but continuous bands of available states. The lowest bands of electrons are tightly bound to the atoms and we are only interested in the uppermost completely filled valence band  $E_v$ , and the (intrinsic) empty conduction band  $E_c$  above. The lasing action will take place between the edges of these two bands and therefore the emitted light will be of a frequency proportional to the band gap  $E_g$  [14].

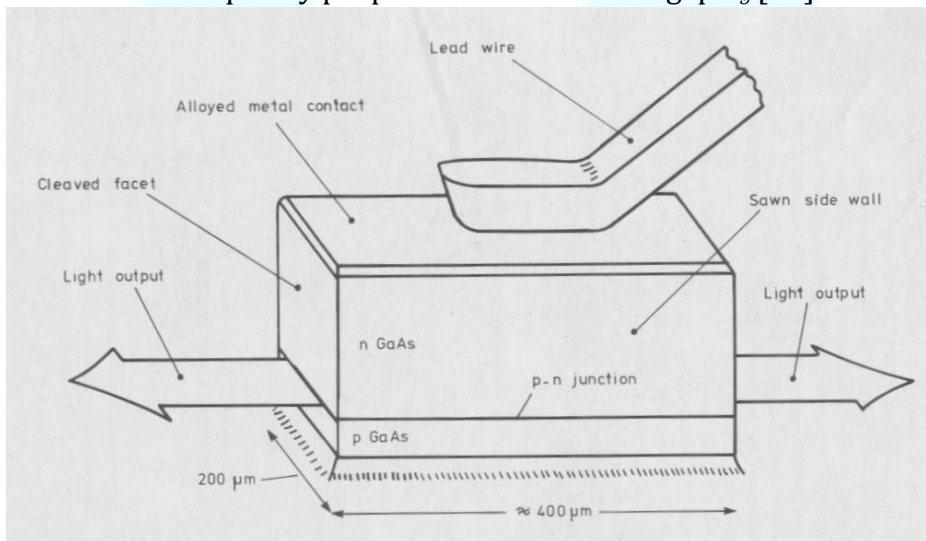

Figure 4: A simple p-n junction laser [17].

Electrons in a crystal may be represented by a propagating plane wave and has a relationship between energy  $E$  and wave vector  $\tilde{k}$  (momentum) as showed in figure 5. A direct band gap means that the lowest electron energy in the conduction band has the same  $\tilde{k}$  as the highest in the valence band.

This means that an electron may jump from  $E_c$  to  $E_v$  (emitting a photon) without changing its momentum [14].

### 3.1 Basic Physics

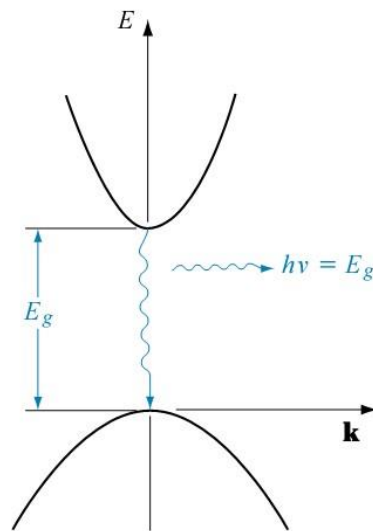

Figure 5: A direct transition accompanied by a photon emission [14].

As in other laser media, it is necessary to create a population inversion in order to obtain a net positive gain. The simplest way of describing a population inversion for semiconductors is to consider the band diagram of a p-n junction as in figure 6. When the Fermi levels for each side lie within their

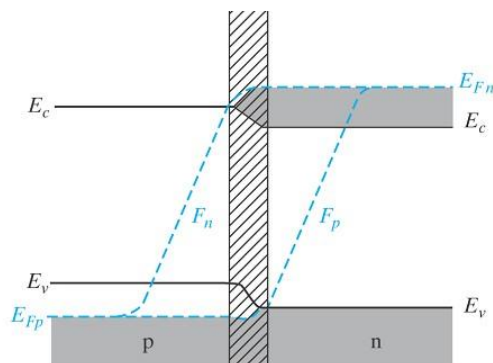

Figure 6: Band diagram of a p-n junction laser under forward bias. The crosshatched region indicates the inversion region at the junction [14].

respective bands (e.g. are heavily doped) and the junction is under forward bias, the Fermi level will not stay as one line over the middle, but split into quasi-Fermi levels  $F_n$  and  $F_p$ . This means that in a thin area, known as the

### 3.2 Homostructure Laser [17]

inversion region, we will have a large amount of both electrons and holes in the same space, allowing a lot of recombinations to take place. Since we have a number of occupied states in both bands, transitions will not only be between the edges of the bands, they may take place with energies ranging from  $h\nu = (F_n - F_p)$  to  $h\nu = E_g$ . Dominant transitions are determined mainly by the resonant cavity, and the fact that recombination radiation near  $h\nu = E_g$  is strong [17].

### 3.2 Homostructure Laser [17]

The simplest and earliest form of a semiconducting laser was based on an n-doped piece of *GaAs*. A portion of the material was p-doped by diffusion to make a p-n junction as seen in figure 7. Since there is only one type of material, this is referred to as the *homostructure* laser. An optical cavity is made by cleaving two of the edges along a crystal plane and roughening the other two. The cleaved edges are often left uncoated, giving a Fresnel reflec-

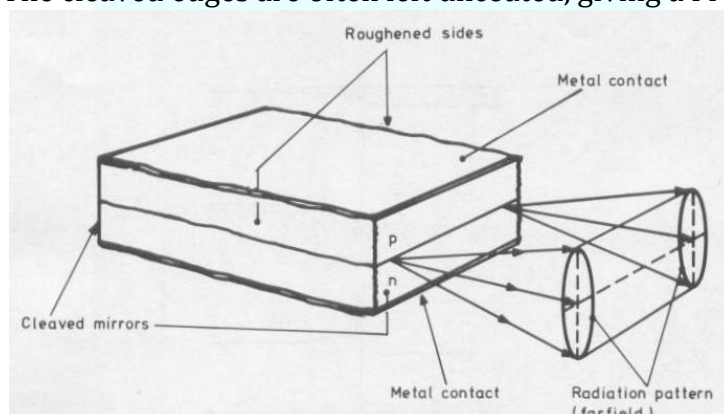

Figure 7: Diagram of a homostructure laser showing light emission from cleaved edge [17].



tivity of about 30% because of the large difference in refractive index. These partial mirrors will create a Fabry-Perot optical cavity and the roughened edges will prevent crosswise specular reflection. The difference in electron density across the junction will produce a graded index of refraction, acting as an optical waveguide. At 80K, the current density  $J_{th}$  needed for this device to lase is of the order of  $500 - 1000 Acm^{-2}$ .  $J_{th}$  is however very temperature sensitive, and has been measured in room temperature to be of the order of  $30-50 kAcm^{-2}$ . One of the main reasons for this high threshold current is that the thickness of the inversion region increases with temperature,



making it necessary to provide a greater volume of injected carriers. This will also lead to a flatter distribution of the refractive index, thus weakening the waveguiding properties.

### 3.3 Heterojunction Laser

The need for maintaining a thin inversion region and good optical waveguiding properties lead to the use of additional materials for laser devices. Improved operation can be achieved by sandwiching layers of materials with different band gap, limiting the spread of carriers and containing the optical wave. As explained in the materials section, the band gap of several ternary and quaternary compounds may be adjusted by varying the composition of the elements. The ideal is to use materials with matching lattice constant, thus eliminating defect states at the junctions [17].

The simplest of the heterostructures, is the *single heterojunction* laser. As in the homostructure, it consist of an active layer of *GaAs* where the p-n junction is located. In addition, a layer of *(AlGa)As* has been grown on top of the p-region as shown in figure 8. This layer will act as a barrier for the injected carriers because it has a higher band gap as shown in figure 9. This junction to a material with a different band gap will also create an abrupt change in refractive index, thus providing better waveguiding properties [17].

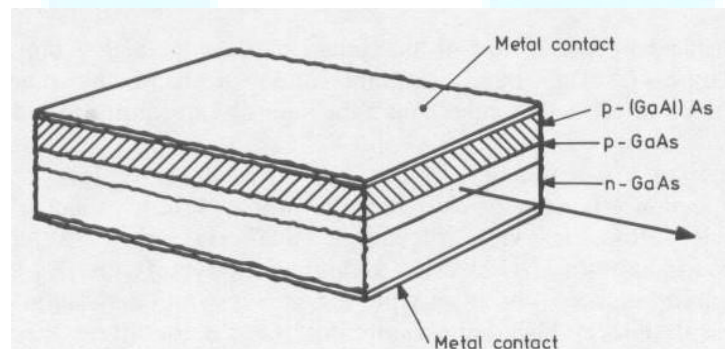

Figure 8: Diagram of a single heterostructure [17].

This structure has the advantage that it is easy to fabricate. P-type *(AlGa)As* may be epitaxially grown on an n-type *GaAs* substrate. By heating it up, dopants will diffuse from the upper layer and in to the substrate, creating a p-doped region of *GaAs*. The threshold current density for this structure is about  $6000\text{--}8000\text{Acm}^{-2}$ . 5-10 times lower than for a homostructure [17].

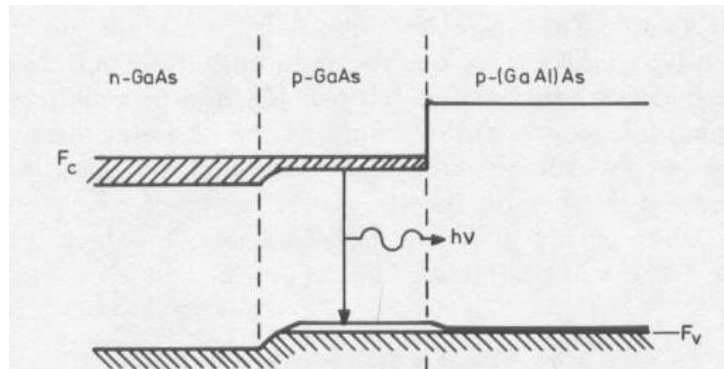

Figure 9: Distribution of conduction and valence bands perpendicular to a p-n junction in a single heterostructure laser [17].

A further lowering of the threshold current can be achieved with the *double heterostructure*. In this structure, the active region is sandwiched between a p- and n-type *AlGaAs*, as shown in figure 10. In this device,  $J_{th}$  may be lowered so that a continuous wave operation can be allowed at room temperature [17].

An even more effective variant of the double heterojunction laser is made by narrowing the injected current to a thin stripe of active material. This increased density over a small area will allow for further reducing of the current [17].

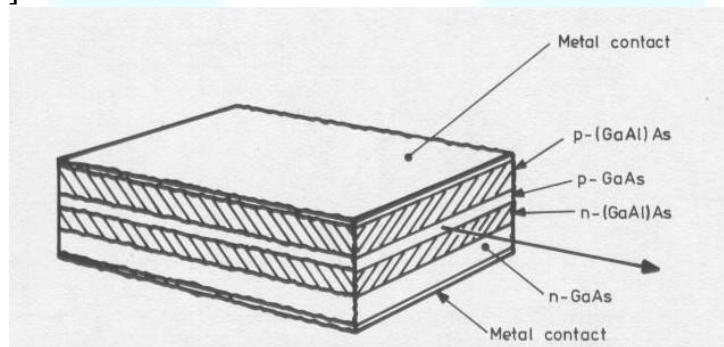

Figure 10: Diagram of a double heterostructure [17].

In all of the so far reviewed laser structures, carrier confinement and waveguiding have both depended on the same junction to a material of different band gap. It is more effective to divide these functions so that each can be optimized. In a *Separate Confinement Channel* structure, as shown in

figure 11, the carrier recombination takes place in a thin region  $d$  whereas the optical waveguiding is confined in a wider region  $w$ . Again considering the  $GaAs-Al_xGa_{1-x}As$ -system, carrier confinement needs a step to a region containing a smaller amount of  $Al$  than the waveguiding needs [14].

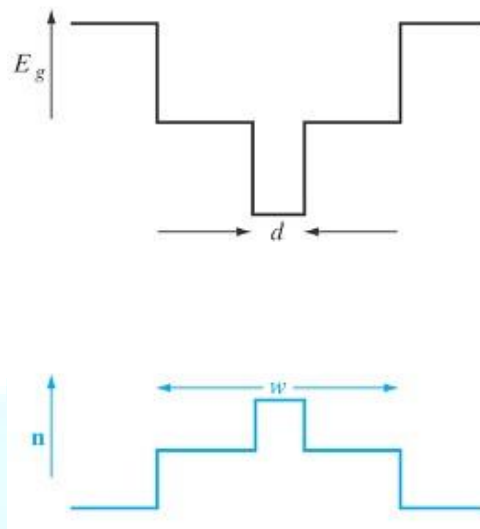

Figure 11: Separate changes in compounds will confine carriers to the thin region  $d$ , and waveguiding will take place in a larger region  $w$  [17].

By gradually changing the  $Al$  content on both sides of the carrier confinement region as shown in figure 12, waveguiding properties compared to that of a fiber optic channel may be achieved [14].

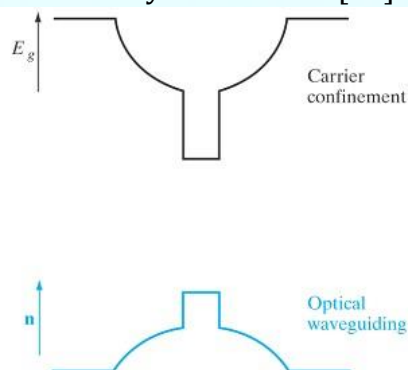

Figure 12: Grading the alloy composition, and therefore the refractive index for better waveguiding and carrier confinement [14].



## 4 Semiconductor Laser Materials

Semiconductor lasers have been made from many different semiconductor materials. The main aim for investigating the use of different materials is to extend the range of possible wavelengths [17].

Most semiconductor lasers are based on compounds from the III and V columns of the periodic table (figure 13). An example is gallium arsenide, which was the first semiconductor laser material. The first semiconductor lasers were made of crystals containing a junction of p- and n-type gallium arsenide. These have now been superseded by alloys containing three or four elements from columns III and V in the periodic table, called ternary or quaternary compound semiconductors. In such compounds the percentage

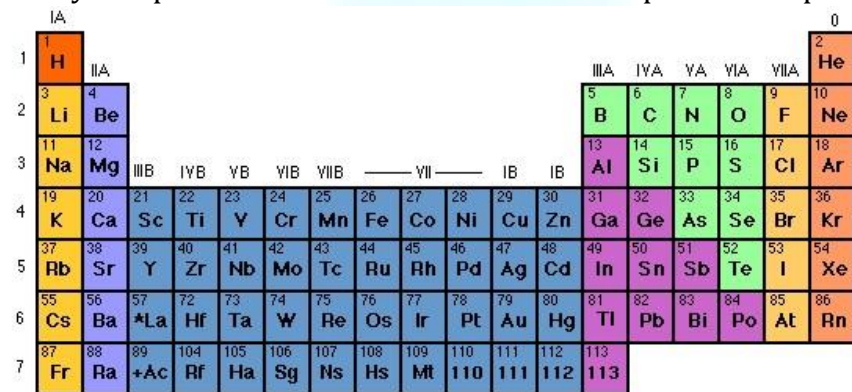

	IA																										0		
1	H																										He		
2	Li	Be																											
3	Na	Mg																											
4	K	Ca	Sc	Ti	V	Cr	Mn	Fe	Co	Ni	Cu	Zn																	
5	Rb	Sr	Y	Zr	Nb	Mo	Tc	Ru	Rh	Pd	Ag	Cd																	
6	Cs	Ba	*La	Hf	Ta	W	Re	Os	Ir	Pt	Au	Hg																	
7	Fr	Ra	+Ac	Rf	Ha	Sg	Ns	Hs	Mt	110	111	112																	

* Lanthanide Series	58	59	60	61	62	63	64	65	66	67	68	69	70	71
	Ce	Pr	Nd	Pm	Sm	Eu	Gd	Tb	Dy	Ho	Er	Tm	Yb	Lu
+ Actinide Series	90	91	92	93	94	95	96	97	98	99	100	101	102	103
	Th	Pa	U	Np	Pu	Am	Cm	Bk	Cf	Es	Fm	Md	No	Lr

Figure 13: Periodic table of elements.

of each component can be varied, so that different material properties can be achieved. Some examples are the ternary compound  $\text{Al}_{1-x}\text{Ga}_x\text{As}$  (aluminium gallium arsenide), and the quaternary compound is  $\text{In}_{1-x}\text{Ga}_x\text{As}_{1-y}\text{P}_y$  (indium gallium arsenide phosphide). In this notation  $x$  and  $y$  are composition parameters that have values between 0 and 1. They define the exact composition of the compound. Thus, the  $\text{Al}_{1-x}\text{Ga}_x\text{As}$  system can vary continuously from AlAs, where  $x=0$ , to GaAs, where  $x=1$  [10].

Some of the most important types of semiconductor lasers are shown in table 1. The most common semiconductor laser material is the alloy aluminium gallium arsenide.



Table 1: Semiconductor Laser Materials [10]

Material	Wavelength range (nm)
$\text{Al}_{1-x}\text{Ga}_x\text{As}$	780-880
$\text{In}_{1-x}\text{Ga}_x\text{As}_{1-y}\text{P}_y$	1150-1650
$\text{Al}_x\text{Ga}_y\text{In}_{1-x-y}\text{P}$	630-680
$\text{In}_{1-x}\text{Ga}_x\text{As}$	980

Figure 14 shows the relationship between the lattice constant and the band gap in a number of ternary solid solutions of III/V compounds. This kind of diagram is useful to show the range of band gaps that can be obtained when you want to change the composition of the solid solution without altering the lattice constant [17].

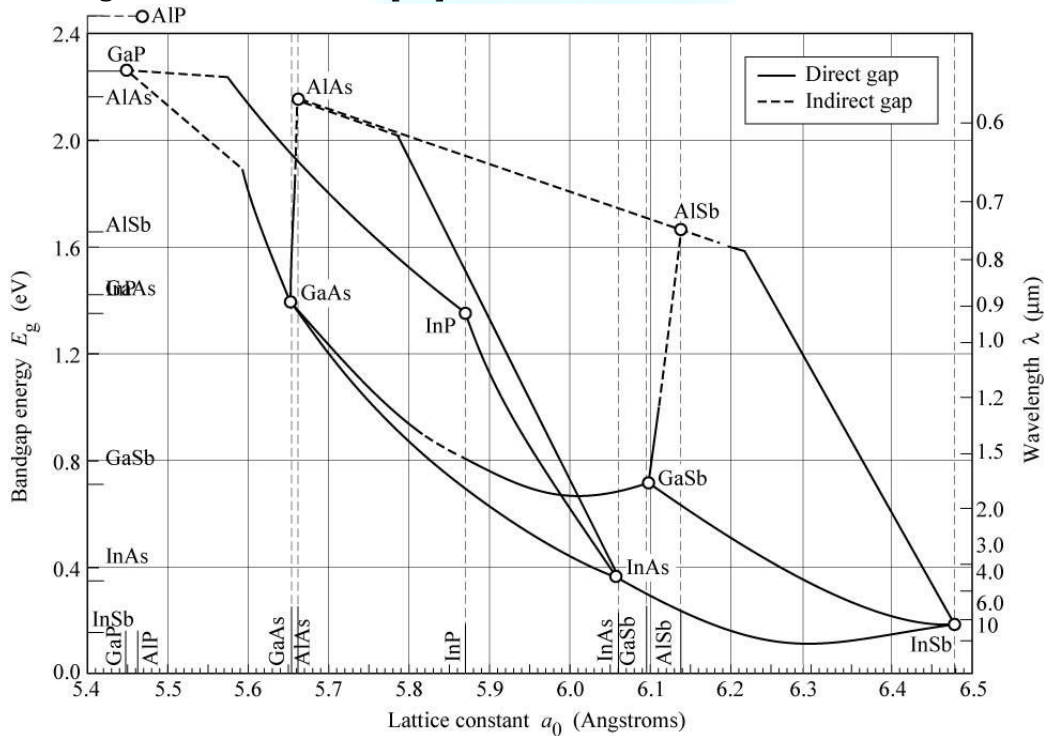

Figure 14: Bandgap energy and lattice constant of various III/V semiconductors at room temperature [12].

There are also other types of semiconductor lasers available, for example compounds from the II and VI columns of the periodic table. These devices operate in the long wavelength infrared region, and they are very expensive and not as common as the III/V compounds. Some commercially available

devices are listed in table 2. The composition parameter  $x$  determines the range of operation for the different compounds [10].

Table 2: Examples of Long-Wavelength Infrared Semiconductor Laser Materials [10]

<b>Material</b>	<b>Wavelength range (<math>\mu\text{m}</math>)</b>
$\text{Pb}_{1-x}\text{Sn}_x\text{Se}$	8-12.5
$\text{PbSe}$	8
$\text{Pb}_{1-x}\text{Eu}_x\text{Se}$	3.5-8

Materials used in semiconductor lasers must be efficient light emitters. The formation of p-n junctions, and in most cases also the formation of heterojunction barriers, must also be possible. Thus, some materials are simply not suitable for practical use in semiconductors. Semiconductors with indirect band gaps are examples of such materials, they are not sufficiently efficient light emitters for practical laser fabrication [14].

The II/VI compounds are generally very efficient light emitters, but junctions are formed with difficulty. Modern techniques like molecular beam epitaxy (MBE) and metal-organic vapor phase epitaxy (MOVPE) makes it possible to grow junctions in ZnS, ZnSe, ZnTe, and alloys of these materials, by the use of N as the acceptor. These materials can be used to make lasers that emit green and blue-green light [14].

## 5 Applications

Lasers are used for many different purposes. Semiconductor lasers are especially attractive because of the demand for cheaper and smaller lasers. They are extremely diverse, used in areas as optical data transmission, optical data storage, metrology, spectroscopy, material processing, pumping solid state lasers, and various kinds of medical treatments [11].



Figure 15: Lasers in a DVD player [13].

Most of us use lasers in everyday life. Semiconductor lasers are for example used to read the information stored in compact discs (CDs) and digital versatile discs (DVDs). The storage density of the discs is inversely proportional to the square of the laser wavelength. Achieving lasers with shorter wavelengths thus makes it possible to store more information on the discs [14]. High spatial coherence is also essential for addressing very small spots in the recording medium [11].

Semiconductor lasers are also used as transmitters in fiber-optic links. These are parts of an optical fiber communications system which provides a data connection between two points [11]. These types of optical cables are for example used between an amplifier and the loudspeakers.



Laser pointers are made from inexpensive semiconductor lasers. Most laser pointers use a small GaInP/AlGaInP laser diode, which emit light in the red region. More expensive laser pointers operate in the green and blue spectral region. Laser pointers are convenient to use during a presentation for example, because they can be used from a large distance and are quite small devices.

They can also be used for certain optical distance measurements [11].

Another application is the use of semiconductor lasers as pump sources for highly efficient solid state lasers. A high electrical-to-optical efficiency of

the semiconductor laser (order of 50%) leads to a high overall power efficiency of the laser [11].

A major goal of the optoelectronics community has been the achievement of high-efficiency red, green and blue emitters. The reason for this is that those are the three primary colours of the spectrum, and by combining them one can form intense white light sources (~500 lumens). The luminous efficiencies can then be about 2 times greater than those of conventional incandescent light bulbs. Light emitting diodes (LEDs) also have much longer lifetimes and much higher energy efficiencies, and if the price can be by ~100 times, they can be used for conventional illumination. This can lead to a significant reduction in global energy demand [14].

## 6 Recent Development: Quantum Dot Lasers

Since the dawn of the semiconductor laser technology in the 1960's, much of the development has been focused on optimizing the layered structure and introducing new alloys. Some do believe that this type of semiconducting laser will be replaced by the quantum dot laser, especially in the field of data chip communication [1].

A quantum dot laser is a semiconductor laser that uses quantum dots in layers as the active gain medium. The laser quantum dots are made from semiconductor nanocrystals. Quantum dots can be as small as 2 to 10 nm, but self-assembled quantum dots are typically between 10 and 50 nm in size, see figure 17. Quantum dots contain a small finite number (1-100) of conduction band electrons and valence band holes (also called excitons) that they can confine the motion of in all three spatial directions. Due to the close packing of charge carriers in quantum dots, they exhibit an electronic structure similar to atoms. So unlike other semiconductor materials used for lasers, quantum dots have a discrete quantized energy spectrum [19, 21].

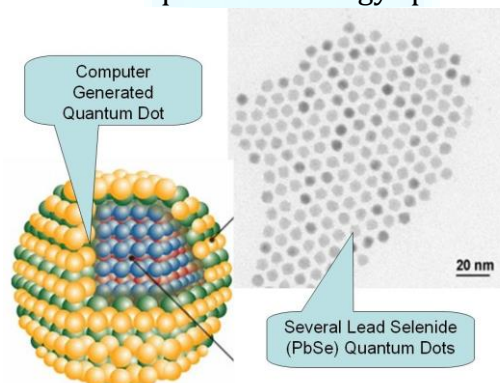

Figure 17: A quantum dot is a semiconductor nanocrystal with 100 to 100 000 atoms within its volume [21, 9].

Quantum dots are useful because their peak emission frequency have an extreme sensitivity to dot size and composition. The reason for this is that their energy levels are not fixed as the band gap in normal bulk semiconductor materials. Excitons have an average internal distance between the electron and hole called the Exciton Bohr Radius, and usually the semiconductor crystals are much larger than this. When the size of the semiconductor crystal is small enough to approach this distance the energy levels can no longer be considered continuous, and under these conditions the semiconductor material can be called a quantum dot. Addition and subtraction of atoms in the quantum dot crystal or changing its surface geometry will change the band gap energy. The quantum dots use this to tune the emission wavelength to extreme precision, see figure 18 [15].

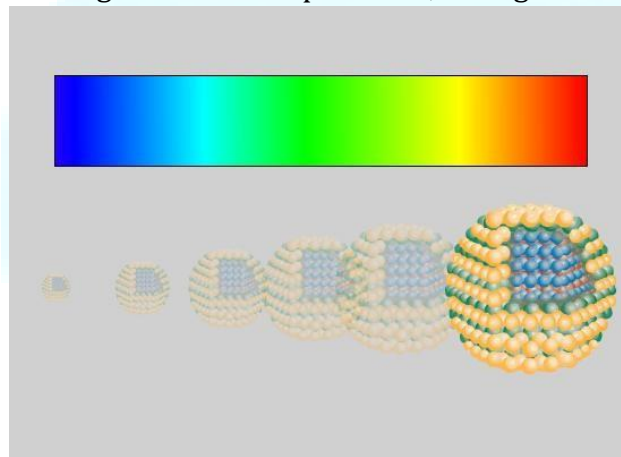

Figure 18: The radiation from quantum dots is often referred to as blue shifted, because the band gap will be larger the smaller the dot.

The first quantum dot laser with high threshold density was demonstrated by Ledentsov and colleagues in 1994[6]. The quantum dot laser need dots that are smaller than 10 – 20 nm and a dot density of one coupled dot pair per  $(200 \text{ nm})^3$ . The dominant decay mechanism in quantum well lasers is nonradiative, emitting optical phonons instead of photons. For quantum dot lasers the radiative decay will dominate the nonradiative because now only multiphonon emissions are possible, and this will improve the laser's efficiency. The pumping will now only need to exceed losses due to spontaneous emission, multiphoton decay and leakage, making the ideal

threshold current determined by the total spontaneous emission rate. The threshold current for quantum dot lasers is several orders of magnitude lower than quantum well lasers [22].

Other observed advantages of quantum dot lasers are narrower emission lines and improvements in modulation bandwidth, relative intensity noise and temperature insensitivity [19, 22]. Fujitsu Limited and a research group at the University of Tokyo developed in 2004 a quantum dot laser with highspeed of 10 gigabits per second across a temperature range of 20 to 70 without electrical current adjustments, see figure 19. This stability over temperature variations can not be achieved with normal semiconductor lasers [8].

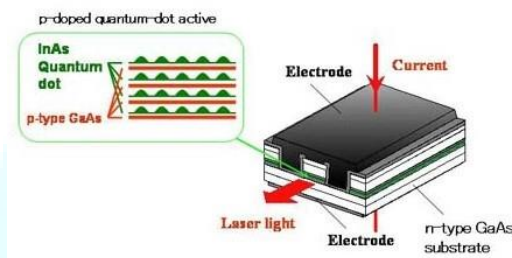

Figure 19: Structure of the 10Gbps quantum dot laser [8].

## **7 Future Aspects**

It is believed that semiconductor lasers will obtain an even stronger position in the future, and a lot of research is going on in different fields. One area with especially large potential is the integration of laser components in existing silicon CMOS technology. If successful this may revolutionize the way information is processed in future computer chips.



