

Reg No.: _____

Name: _____

APJ ABDUL KALAM TECHNOLOGICAL UNIVERSITY
B.Tech Degree 7th semester (S,FE) Exam April 2025 (2019 Scheme)

Course Code: EET401

Course Name: ADVANCED CONTROL SYSTEMS

Max. Marks: 100

Duration: 3 Hours

PART A

Answer all questions, each carries 3 marks.

Marks

- | | | |
|----|--|-----|
| 1 | How do you choose the state variables for state space modelling? | (3) |
| 2 | Obtain the state model of the system described by the transfer function given as | (3) |
| | $\frac{Y(s)}{U(s)} = \frac{10(S + 4)}{S(S + 1)(S + 3)}$ | |
| 3 | State and prove any three properties of state transition matrix. | (3) |
| 4 | Derive the solution of homogeneous state equation | (3) |
| 5 | Consider the system described by the state model, $\dot{x} = Ax + Bu$ and $y = Cx$ | (3) |
| | A state feedback controller is employed with control law $u = -kx$ where k is the state feedback controller gain matrix. Obtain the modified state model of the system and give the block diagram. | |
| 6 | Discuss the procedure to test the controllability and observability using the PBH method. | (3) |
| 7 | Give the stability conditions based on describing function analysis. | (3) |
| 8 | How the non-linearities are classified? Give examples | (3) |
| 9 | Explain the terms phase plane, phase trajectory and phase portrait | (3) |
| 10 | Check the sign definiteness of the matrix $A = \begin{bmatrix} 1 & 2 & 1 \\ 2 & 4 & 2 \\ 1 & 2 & 0 \end{bmatrix}$ | (3) |

PART B

Answer any one full question from each module, each carries 14 marks.

Module I

- 11 a) Derive the state model of the electrical circuit shown below (9)

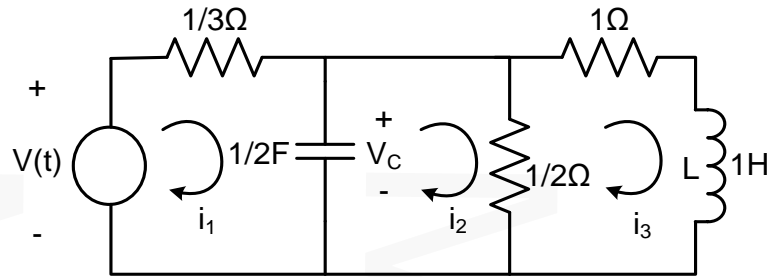

b) Using the similarity transformation, diagonalize the matrix $A = \begin{bmatrix} 0 & 1 \\ -2 & -3 \end{bmatrix}$ (5)

OR

12 a) Derive the state model of the mechanical system shown below (9)

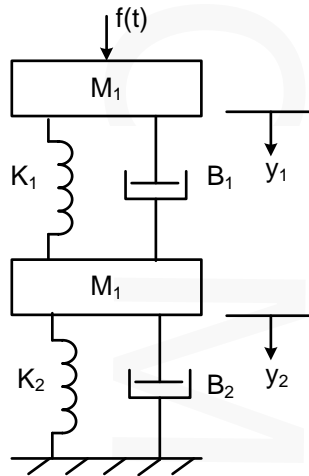

b) Determine the state model of the system shown in the signal flow graph given below (5)

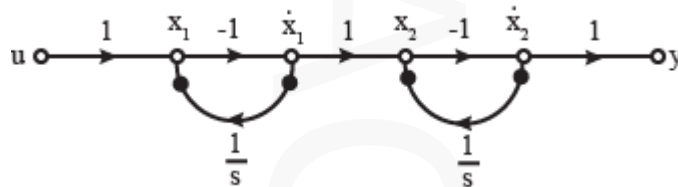

Module II

13 a) Obtain the unit step response of the system describe by the state model given below for the initial condition, $x(0) = \begin{bmatrix} 0 \\ 0 \end{bmatrix}$ (8)

$$\dot{x} = \begin{bmatrix} 0 & 1 \\ -6 & -5 \end{bmatrix} x + \begin{bmatrix} 0 \\ 1 \end{bmatrix} u$$

$$y = [1 \quad 0] x$$

b) Compute the state transition matrix using Cayley-Hamilton theorem for the system with system matrix $A = \begin{bmatrix} 0 & 1 \\ -1 & -2 \end{bmatrix}$ (6)

OR

- 14 a) Determine the transfer function of the system describe by the state model given below (8)

$$\dot{x} = \begin{bmatrix} 0 & 1 & 0 \\ -1 & -1 & 0 \\ 1 & 0 & 0 \end{bmatrix} x + \begin{bmatrix} 0 \\ 1 \\ 0 \end{bmatrix} u$$

$$y = [0 \quad 0 \quad 1]x$$

- b) Explain Cayley-Hamilton theorem with an example (6)

Module III

- 15 a) Consider the state space system expressed by the signal flow diagram shown in the figure. Test the controllability using Kalman's method (7)

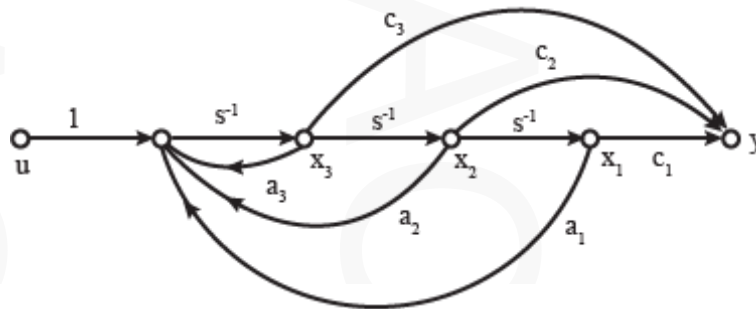

- b) A regulator has the plant described in the state model given below (7)

$$\dot{x} = \begin{bmatrix} 0 & 1 \\ 20.6 & 0 \end{bmatrix} x + \begin{bmatrix} 0 \\ 1 \end{bmatrix} u$$

$$y = [1 \quad 0]x$$

Design a state feedback controller with the control law $u = -KX$ such that the closed loop system has the eigenvalues at $-1.8 \pm j2.4$

OR

- 16 a) Test the controllability and observability of the system shown in the block diagram given below (8)

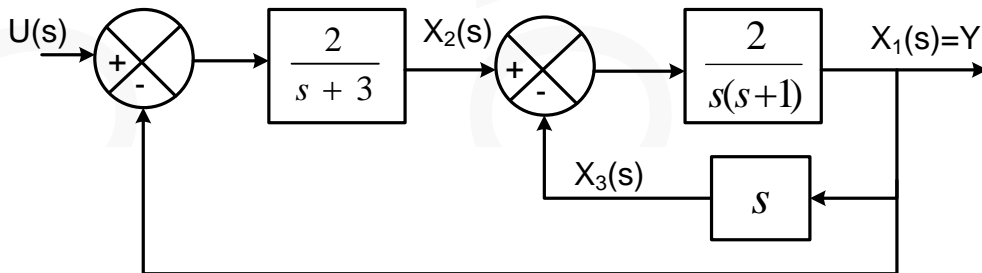

- b) Design a full order state observer for the system described in the state model given below (6)

$$\dot{x} = \begin{bmatrix} 0 & 20.6 \\ 1 & 0 \end{bmatrix} x + \begin{bmatrix} 0 \\ 1 \end{bmatrix} u$$

$$y = [0 \quad 1]x$$

The desired eigenvalues of the observer matrix are $\mu_1 = -10$ and $\mu_2 = -10$

Module IV

- 17 a) Determine the frequency and nature of the limit cycle for the unity feedback system given below. (10)

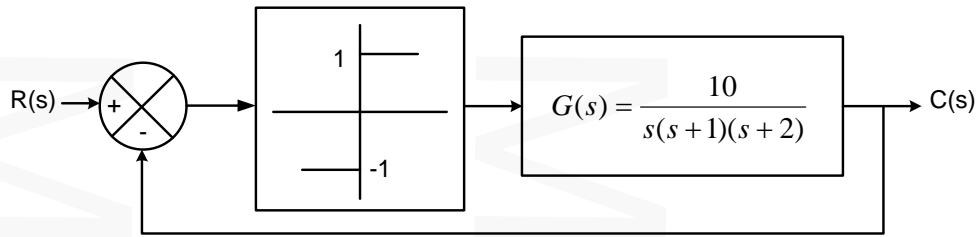

- b) State the assumptions made in the describing function method of analysis (4)

OR

- 18 a) Derive the describing function of the non-linearity shown below (8)

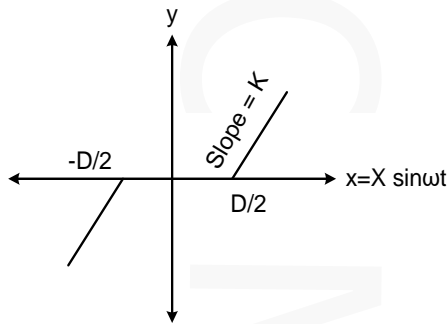

- b) Explain the following i) Jump resonance ii) Limit cycle iii) Frequency entrainment (6)

Module V

- 19 a) Explain the stable and unstable limit cycles using necessary sketches. (4)
- b) A linear system is describe by the state equation $\dot{x} = Ax$ where $A = \begin{bmatrix} -4K & 4K \\ 2K & -6K \end{bmatrix}$ (10)
- Using the Lyapunov method, find the restrictions on the parameter K to guarantee the system stability.

OR

- 20 a) Determine the singular points of the system described by the differential equation (6)

$$\ddot{x} + 4\dot{x} - 2.5x^2 + 5x = 0$$

- b) Determine the stability of the system described by the state equation given below (8)
- using Lyapunov method. Select the Lyapunov function as

$$V(x) = x_1^4 + (x_1 + x_2)^2$$

$$\dot{x}_1 = x_2$$

$$\dot{x}_2 = -x_2 - x_1^3$$
